

PREFACE

THANK YOU FOR PURCHASING A TYM 2400, 2400H, 2510, 2510H, 2610H TRACTOR.

► BEFORE USE, READ AND UNDERSTAND THIS MANUAL COMPLETELY.

1. After reading this manual, keep it close to the tractor for immediate reference.
2. Anyone operating this tractor should review this manual.
3. In case this manual is lost or damaged, please contact your nearest authorized dealer for a copy.
4. Some parts of this product may have been changed for the improvement of quality or for safety reason.
5. In this case, the photographs or drawings of such parts in this booklet may not be the same as the actual parts installed on this product.
6. If you find anything in this manual unclear or in need of further explanation, please contact your authorized dealer for inquiry.

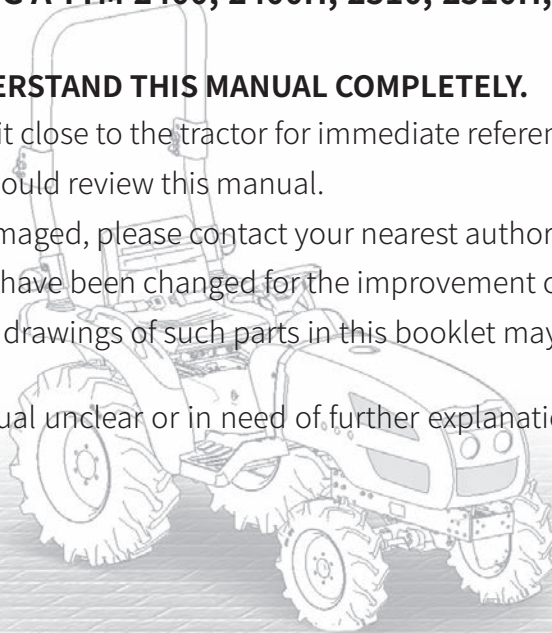
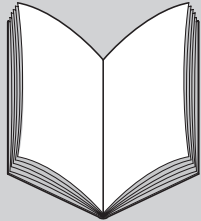

TABLE OF CONTENTS

SECTION



● GENERAL PRECAUTIONS.....	1
● ABOUT WARRANTY	2
● OVERVIEW OF THE TRACTOR.....	3
● FUNCTIONS.....	4
● OPERATION & WORK	5
● MAINTENANCE AFTER WORK	6
● PERIODIC MAINTENANCE AND ADJUSTMENT	7
● TROUBLE SHOOTING.....	8
● SPECIFICATIONS	9
● EMISSIONS CONTROL WARRANTY	10
● INDEX	11

TABLE OF CONTENTS

GENERAL PRECAUTIONS.....	1-1	OVERVIEW OF THE TRACTOR.....	3-1
TO ENSURE SAFE OPERATION.....	1-2	EXTERIOR VIEW.....	3-2
BEFORE USING THE MACHINE	1-2	FUNCTIONS.....	4-1
WHILE WORKING.....	1-11	SWITCHES AND LEVERS.....	4-2
AFTER USING THE MACHINE	1-13	MAIN KEY SWITCH	4-2
PRECAUTION FOR PROLONGED STORAGE	1-15	THROTTLE LEVER.....	4-3
PRECAUTIONS IN INCLINED AREA	1-17	ACCELERATOR PEDAL.....	4-3
MAINTENANCE BEFORE OPERATING.....	1-18	TURN SIGNAL S/W	4-4
OTHERS.....	1-19	HEAD LAMP & HORN S/W	4-4
LOCATION OF SAFETY DECALS	1-26	HAZARD LAMP SWITCH	4-4
ABOUT WARRANTY	2-1	INSTRUMENT PANEL	4-5
WARRANTY	2-2	TACHOMETER.....	4-5
TROUBLE SHOOTING	2-2	HOUR METER.....	4-6
		PTO POSITION	4-6
		PRE-HEAT LAMP.....	4-6
		BATTERY CHARGE LAMP.....	4-7
		ENGINE OIL PRESSURE LAMP	4-7
		FUEL GAUGE	4-7

TABLE OF CONTENTS

WATER TEMP GAUGE	4-8	OTHERS.....	4-17
HEAD LAMP (HIGH BEAM)	4-8	SEAT BELT	4-17
PEDALS	4-9	TAIL LAMP	4-18
CLUTCH PEDAL	4-9	BRAKE LAMP	4-19
BRAKE PEDAL	4-10	OPERATION & WORK	5-1
DIFFERENTIAL LOCK PEDAL.....	4-10	CHECKING BEFORE OPERATION.....	5-2
F-R HST DRIVE PEDAL.....	4-11	STARTING / STOPPING THE ENGINE	5-9
CRUISE CONTROL UNIT	4-11	TO START THE ENGINE.....	5-10
LEVER OPERATION (R).....	4-13	TO STOP THE ENGINE	5-12
MAIN GEAR SHIFT LEVER.....	4-13	TO RAISE OR LOWER THE IMPLEMENT	5-12
POSITION CONTROL LEVER	4-14	ADJUSTING THE LOWERING SPEED OF	
MFWD LEVER.....	4-14	THE IMPLEMENT	5-13
LEVER OPERATION (L)	4-15	DRIVING ON THE ROAD	5-13
RANGE SHIFT LEVER.....	4-15	DRIVING ON THE SLOPE	5-14
PTO LEVER	4-16	ENTERING AND LEAVING THE PAVEMENT	5-15
FLOW CONTROL VALVE.....	4-17		

TABLE OF CONTENTS

TURNING ON THE PAVEMENT	5-15	ROPS FOLDING METHOD	5-26
DIFFERENTIAL LOCK	5-16	HOW TO FOLD DOWN THE ROPS	5-26
TRACTOR LOADING /UNLOADING	5-17	MAINTENANCE AFTER WORK.....	6-1
INSTALLING 3POINT LINK.....	5-18	MAINTENANCE AFTER WORK	6-2
PRECAUTIONS FOR ATTACHING THE IMPLEMENT	5-19	MAINTENANCE FOR PROLONGED STORAGE	6-2
AUX. HYDRAULICS	5-20	PERIODIC MAINTENANCE AND ADJUSTMENT	7-1
ADJUSTING WHEEL TREAD	5-21	PERIODIC MAINTENANCE AND ADJUSTMENT....	7-2
POWER STEERING	5-21	PERIODIC MAINTENANCE SCHEDULE	7-3
TOWING INSTRUCTIONS.....	5-22	OIL, GREASE AND ANTI-FREEZE CHART	7-5
PTO SPECIFICATIONS & PRECAUTIONS.....	5-22	FUEL, OIL AND COOLANT CHART	7-5
LOADER OPERATION	5-23	OPENING AND CLOSING OF HOOD AND SIDE COVERS.....	7-7
CARRYING THE LOAD.....	5-24		
HANDLING LARGE HEAVY OBJECTS	5-25		

TABLE OF CONTENTS

CHECKING AND CHANGING OIL..... 7-7

ENGINE OIL	7-7
TRANSMISSION OIL	7-8
FRONT AXLE.....	7-9

FILTERS / COOLANT REPLACEMENT7-10

ENGINE OIL FILTER	7-10
TRANSMISSION OIL FILTER	7-11
FUEL FILTER.....	7-11
DRAINING AIR IN FUEL LINE	7-12
COOLANT	7-12

OTHERS.....7-14

RADIATOR SCREEN & AIR CLEANER ELEMENT	7-14
BATTERY	7-15
PIPES AND HOSES.....	7-15
ELECTRICAL CABLES	7-16
GREASING	7-17
CLUTCH	7-17
STEERING WHEEL.....	7-18

BRAKE	7-18
FAN BELT	7-19
TOE-IN.....	7-20
FUSE & FUSIBLE LINKS.....	7-21
COLOR OF EXHAUST GAS	7-21
TIRES.....	7-22

TROUBLE SHOOTING..... 8-1

ENGINE..... 8-2

CLUTCH AND BRAKE..... 8-4

HYDRAULIC SYSTEM..... 8-5

ELECTRICAL SYSTEM..... 8-6





SPECIFICATION 9-1

TAIL LAMP..... 9-2

INDEX.....10-1

SAFETY AND VEHICLE DAMAGE WARNING

The instructions given with the following marks are very important for your safety.

 DANGER	Failure to observe the instruction given with this mark may result in death or injury.
 WARNING	Failure to observe the instruction given with this mark may expose you to the risk of death or injury.
 CAUTION	Failure to observe the instruction given with this mark may expose you to injury. <ul style="list-style-type: none">• The section, “ To Ensure Safe Operation,” on the following pages details safety points to be observed to ensure safe operation of your tractor.• Please make sure you read it carefully before operating the tractor.
NOTE	This instruction is to give an additional description to operator so that he/she can operate the machine more effectively.
 IMPORTANT	Read this Manual for correct and safe use of the product. Failure to use the product properly may result in an accident. Keep this Manual close to the tractor after you have read it.

SYMBOL MARKS OF CONTROLLER

This manual includes symbol marks of the controller to simplify operations for maneuverability and maintenance. These meanings are as below, so carefully read it for a proper function.



Turn signal Lamp (LH)



High Beam



Preheat



Turn signal Lamp (RH)



Battery Charging Lamp



Engine Oil Pressure Lamp

"USE AND DISPOSAL" POLICY CONCERNED WITH ENVIRONMENT PRESERVATION

We try our best to preserve the environment and are always concerned about our environmental impact at each step of planning, development, production, distribution, use and disposal of products, and for our overall operations through an “environmentally friendly” management system. We comply with international environmental regulations, environmental regulations designated by country and local authorities and other requirements with which we are in agreement, and we work towards the prevention of environmental pollution and the conservation of resources. We provide environmental education and have an awareness campaign to raise environmental awareness among all our employees and members of the supporting companies.

We introduce the “Use and Disposal” policy concerned with environment preservation as follows.

1. Please read the operator’s manual thoroughly for global environment protection. Overload on the machine shortens the product life and increases the harmful exhaust gas, which causes air pollution due to the incomplete combustion.
2. When replacing various fluids (for engine, transmission, hydraulics, etc.) by yourself, don’t dispose the used oil to anywhere not recommended. It can pollute the ground and water. Please contact your local dealer to dispose it legally.
3. Observe the operator’s manual and store or dispose the waste product properly. Rust, oil, etc. leaked from waste product improperly stored can pollute the ground and water. Accordingly for a waste product disposal, contact the necessarily “approved waste collection and recycling facility” to discard the used materials legally.

1. GENERAL PRECAUTIONS

TO ENSURE SAFE OPERATION.....	1-2
BEFORE USING THE MACHINE	1-2
WHILE WORKING.....	1-11
AFTER USING THE MACHINE	1-13
PRECAUTION FOR PROLONGED STORAGE	1-15
PRECAUTIONS IN INCLINED AREA	1-17
MAINTENANCE BEFORE OPERATING	1-18
OTHERS.....	1-19
LOCATION OF SAFETY DECALS	1-26

TO ENSURE SAFE OPERATION BEFORE USING THE MACHINE

Make sure to observe the instruction given in this section to avoid equipment failure or personal injury or death.



⚠ WARNING

Beware of exhaust gas:

- Do not start or operate the engine in an enclosed space. And you should only operate engine outside or in a well ventilated area.

[Otherwise]

The exhaust gas can cause intoxication and lead to fatal consequences.

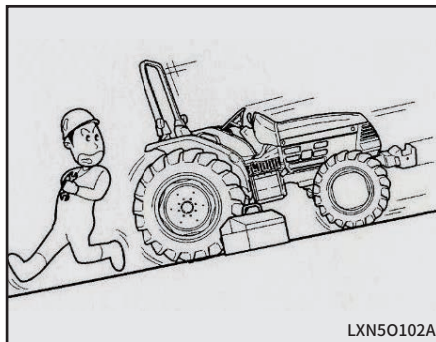

⚠ WARNING

Maintenance on a flat and safe place:

- Selecting a flat and safe location to secure the tractor in place will not cause a risk to people passing by. Before carrying out the maintenance. Block the front and rear tires to prevent moving while servicing tractor.

[Otherwise]

An unexpected accident may occur, such as overturning of the tractor.

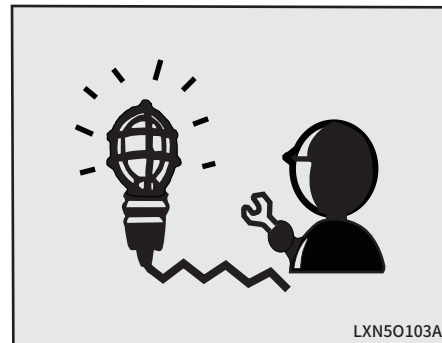

⚠ WARNING

Carry out maintenance in a well-lit place:

- Make sure work area is properly lighted.
- Use safety work lights with protection covering.

[Otherwise]

An unexpected accident may occur, possibly fire or explosion.

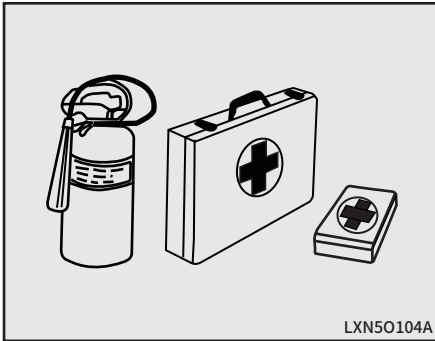

⚠ WARNING

Prepare for emergencies:

- Keep a first aid kit and fire extinguisher handy at all times while operating equipment.

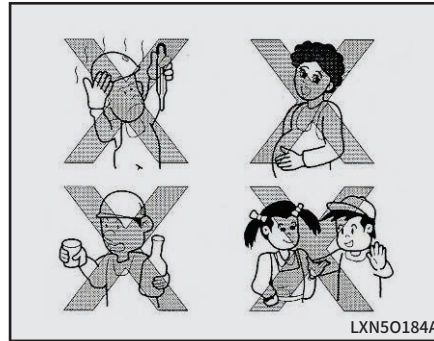

⚠ WARNING

Do not drive if you are:

- Unable to concentrate because of fatigue, under treatment of medicine.
- Under the influence on alcohol.
- Pregnant.
- Under the age of 18.

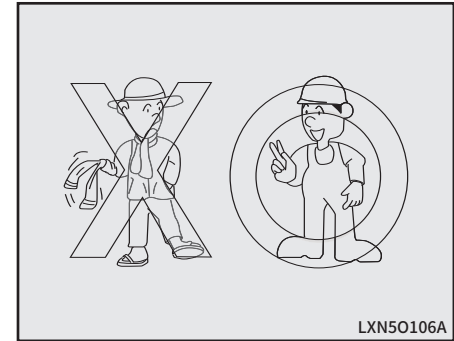

⚠ WARNING

Wear the appropriate clothing when operating equipment

- Do not wear loose fitting clothes.
- Do wear proper footwear with anti-slip shoes, safety helmet and protective comfortable clothes to allow freedom of movement.

[Otherwise]

You will be exposed to a risk of being entangled with equipment resulting in injury.

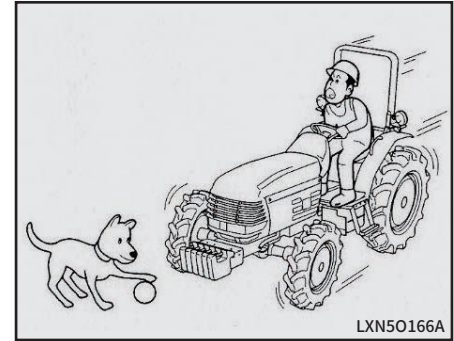
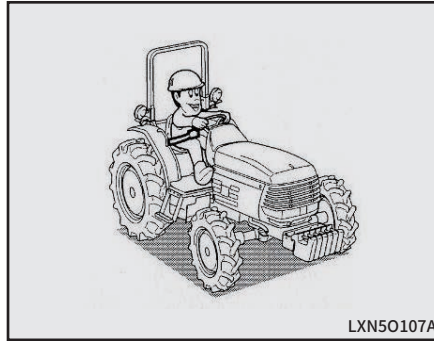
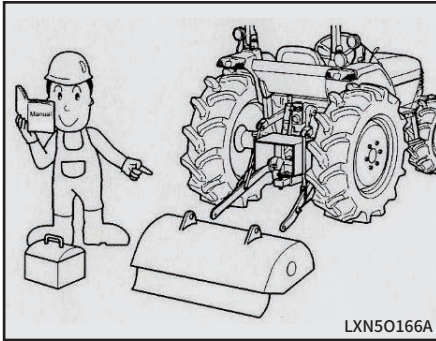

⚠ WARNING

Use only recommended implements:

- Be sure to use only implements which are recommended by manufacturer.

[Otherwise]

An unexpected accident may occur or tractor may not perform properly.

⚠ WARNING

Fasten your seat belt at all times.

- Keep your seat belt fastened at all times while operation of tractor.

[Otherwise]

You will be exposed to a risk of death or serious injury if the tractor overturns.

⚠ WARNING

Check the safety of the tractor and start to move slowly:

- Only operate tractor while people or animals are at safe distance away.
- Check around the tractor, start the engine, and move slowly.

[Otherwise]

There is a risk of injury.

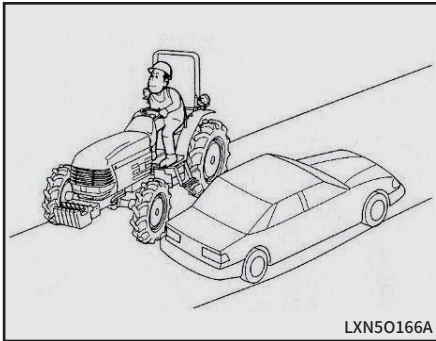

⚠ WARNING

Pay attention to the shoulder of the road :

- When moving along the unpaved road with ditches or slanted sides, pay attention to the shoulders.

[Otherwise]

There is a risk of falling over.

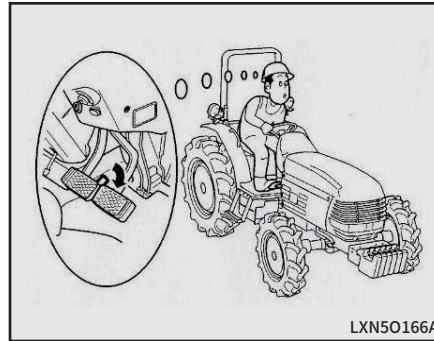

⚠ WARNING

Connect the brake pedals when driving on a road:

- Make sure to connect the brake pedals when driving on a road.

[Otherwise]

There is a danger of abrupt turning or overturning due to one-sided braking when the brake pedal is depressed.

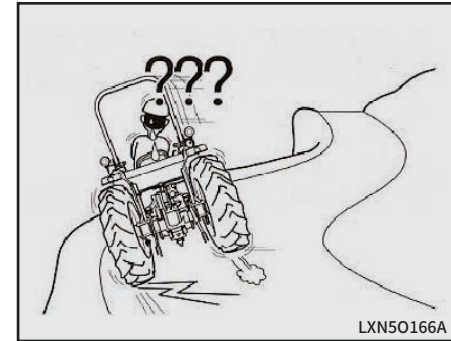

⚠ WARNING

Avoid braking, or turning at excessive Speed:

- Reduce throttle speed when making a turn, apply brake when driving on a hilly or curved roads.

[Otherwise]

There is a risk of overturning.

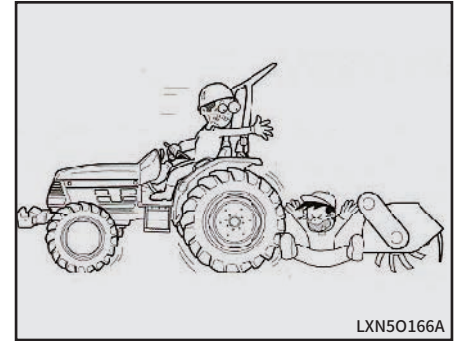
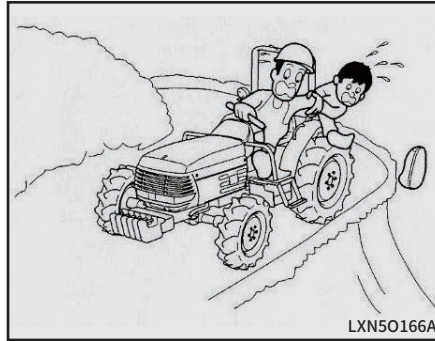
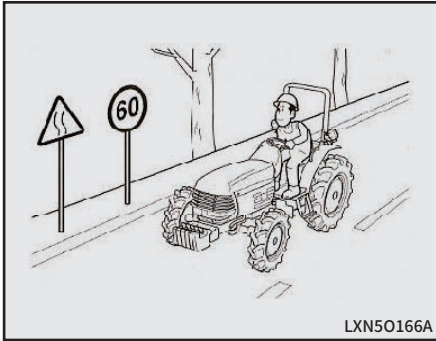

⚠ WARNING

Observe traffic regulations and drive safely:

- When driving on the road, observe the traffic regulations and wear a helmet.

[Otherwise]

There is a danger of accident or injury.

⚠ WARNING

Only driver should be aboard the tractor while in operation:

- This tractor is designed to allow only one operator. The driver must not allow anyone else to get on the tractor. (Especially, children)

[Otherwise]

An unexpected accident may occur.

⚠ WARNING

Do not allow anyone near while operating the tractor or implement:

- When engaging or disengaging the implement by moving the tractor, make sure that no one is allowed around the tractor or between the implement or attachment and the tractor.

[Otherwise]

There is a danger of accident or injury.

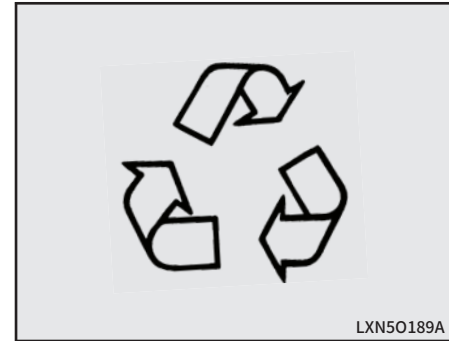
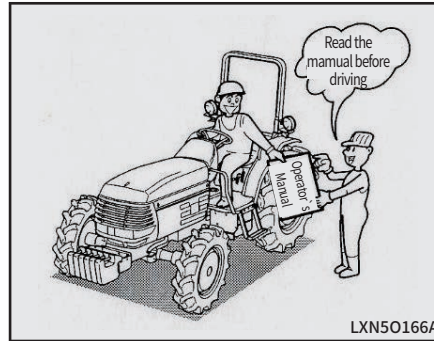
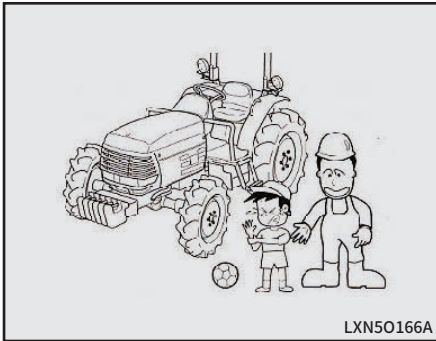

⚠ WARNING

Keep children away from the tractor:

- Fully warn children and keep them away from the tractor at all times.

[Otherwise]

There is a risk of injury.

⚠ WARNING

Properly train anyone operating:

- Before allowing other people to use your tractor, explain how to operate and have them read this manual.

[Otherwise]

There is a danger of death, serious injury, or damage to the tractor.

Treatment of hazardous materials

- Properly discard hazardous materials.
- Hazardous materials from tractor are the following: Coolant, brake oil, oil, filter elements, battery and so on.
- When draining fuel, oil or other liquids, use a container without holes. Do not dispose of chemicals on the ground or in rivers or waterways

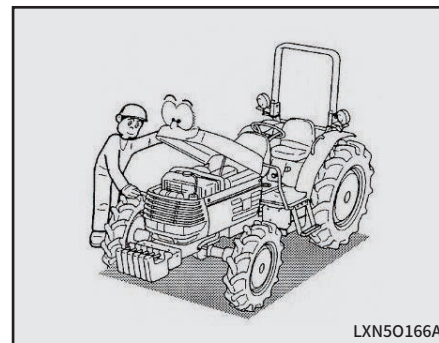
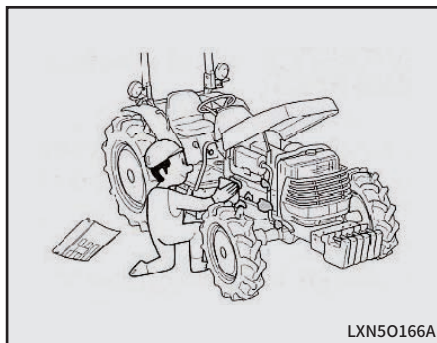
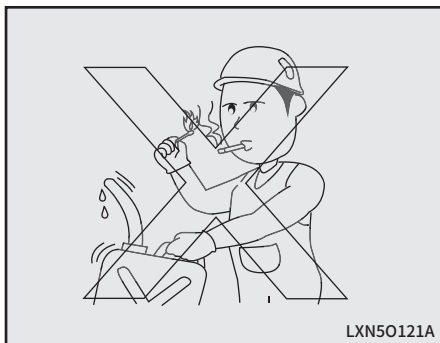

⚠ DANGER

No smoking or open flame when fueling:

- Absolutely no lit cigarettes, matches, or lighters anywhere near when fueling the tank.

[Otherwise]

Fire or explosion may occur.

⚠ WARNING

- Every day before operating the tractor, check for straws, dust, fuel, or other residue on and around the muffler and the engine and remove them.

[Otherwise]

It may result in a fire.

⚠ WARNING

Frequently inspects the electrical parts and wiring:

- Inspect electrical wiring contact insulation to avoid shorting or spark.

[Otherwise]

There is a risk of fire due to short circuit.

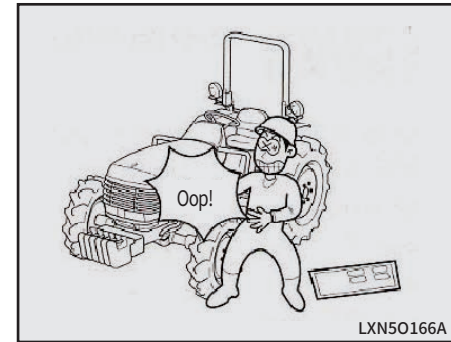
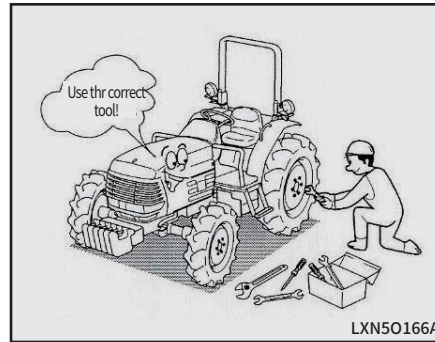
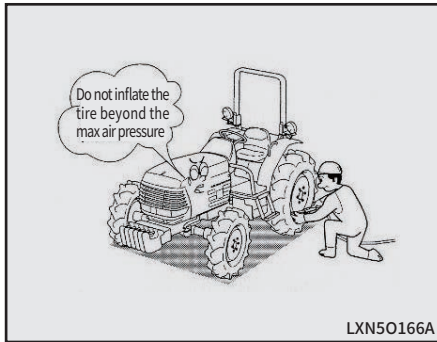

⚠ CAUTION

Do not over inflate tires:

- When filling tires with air, do not inflate it beyond the maximum pressure stated in this booklet.

[Otherwise]

The tire may blow out, causing an injury.

⚠ CAUTION

Use correct tools:

- Use proper tools to carry out all maintenance procedure.

[Otherwise]

There is a danger of accident due to poor maintenance.

⚠ CAUTION

Secure hood and side covers before operate tractor:

- After opening the hood for checking or maintenance, make sure to put them in their place.

[Otherwise]

There is a risk that you may get entangled in the tractor or get injured.

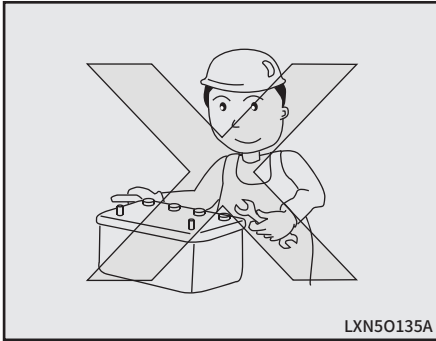

LXN50135A

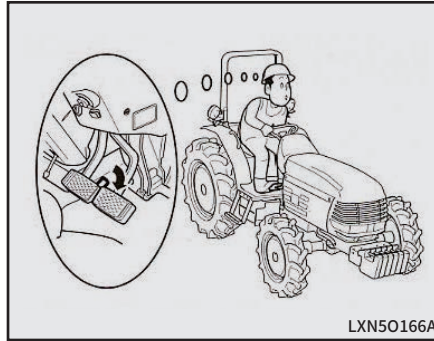

LXN50166A

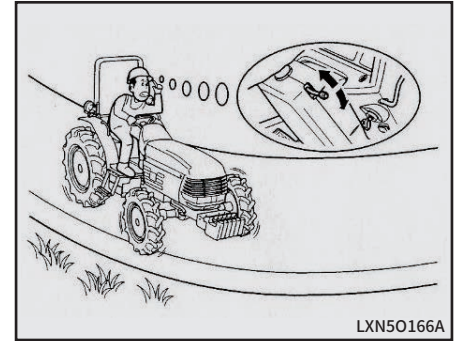

LXN50166A

⚠ CAUTION

Observe correct procedures when installing or removing the battery:

- Connect the (+) terminal first when installing the battery, and disconnect the (-) terminal first when removing it.

[Otherwise]

There is a risk of burn or fire due to short circuit.

⚠ WARNING

Connect dual brake pedal before moving tractor:

- Check if the brakes work properly and evenly on both sides or if the steering wheel is loose.

[Otherwise]

There is a risk of accident.

⚠ WARNING

Lock steering tilt before moving tractor:

- Except when you adjust the steering wheel, make sure that the tilt lever is placed in the <Lock> position.

[Otherwise]

The tractor may not turn to the direction you want and may cause an accident.

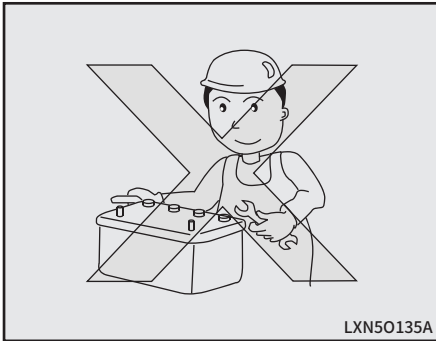

⚠ DANGER

Avoid contact with the battery solution:

- Be careful that your body or your clothes do not come in contact with the battery solution. If you come in contact with the battery solution, rinse it off with water immediately.

[Otherwise]

You may get burnt or your clothes may be damaged.

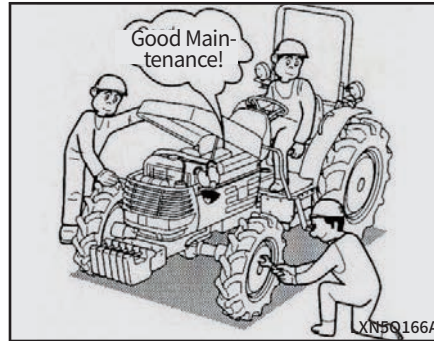

⚠ CAUTION

- Perform periodic maintenance, keep each part of the tractor in normal condition.
- Make sure to replace all hydraulic hoses and brake hoses once every two years.

[Otherwise]

There is danger of accident or equipment failure due to poor maintenance.

WHILE WORKING

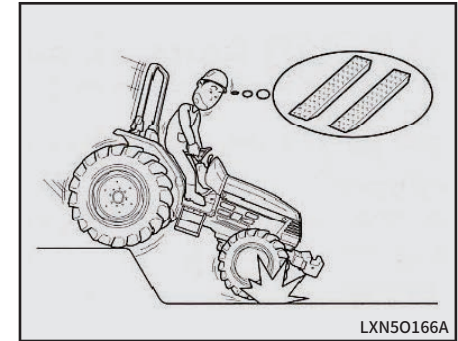

⚠ WARNING

Use the loading ramps when crossing a ditch or a dike:

- Be sure to use the loading ramps when crossing a ditch or dike, or when passing through soft land. The loading ramps must be suitable for the tractor in width, length and strength.

[Otherwise]

There is a risk of accident that the tractor may slip or turn over.

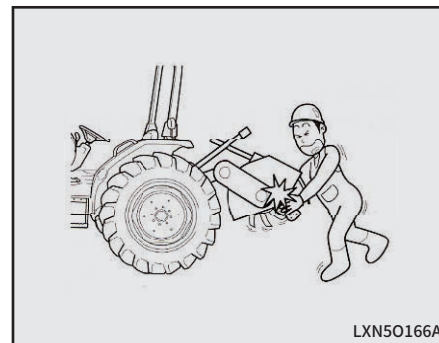
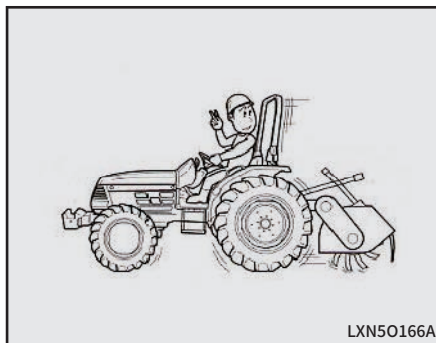
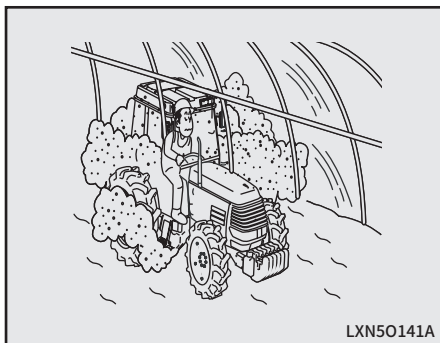

⚠ WARNING

Properly ventilate when working in a green house:

- Ventilate the area to let out the exhaust gas.

[Otherwise]

The exhaust gas can cause intoxication and lead to fatal consequences.

⚠ WARNING

- Pay attention and keep hands on the steering wheel while driving.

[Otherwise]

There is a risk of accident to injury.

⚠ WARNING

- Stop the engine when removing grass, etc. from the blades of the cultivator.

[Otherwise]

There is a danger that you will get entangled in the cultivator or sustain a serious injury.

AFTER USING THE MACHINE

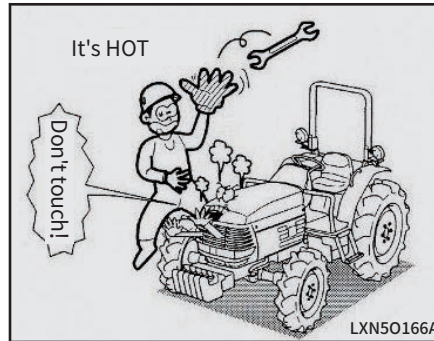
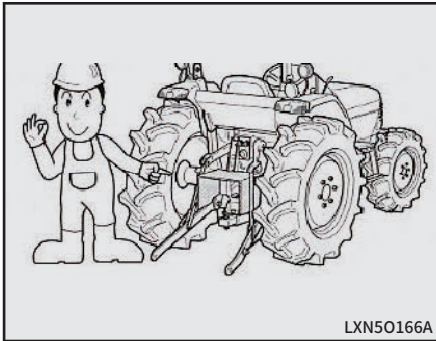

⚠ CAUTION

Cover the PTO shaft when not in use.

- When the PTO shaft is not in use, apply grease to it and keep it covered.

[Otherwise]

There is a risk that you may get entangled or get injured.

⚠ CAUTION

- During operation and right after the engine is turned off, the muffler is very hot. Avoid touching it, as you may get burnt.

[Otherwise]

There is a risk of getting burnt.

⚠ CAUTION

Be careful of high oil pressure:

- Make sure that the hydraulic coupling or the hose is not loose or damaged. Before separating the hydraulic coupling or the hose, eliminate the high pressure inside the hydraulic system.

[Otherwise]

The oil under high pressure may cause damage to the skin or injury.

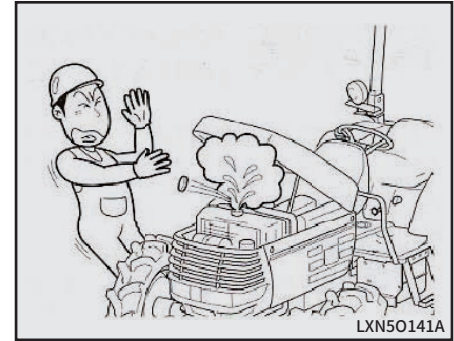
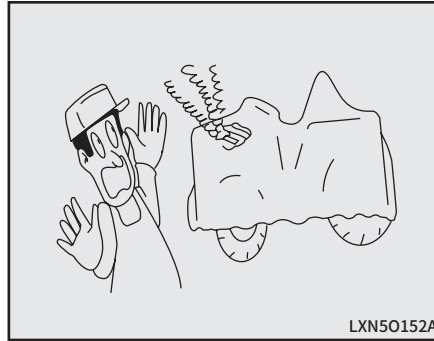
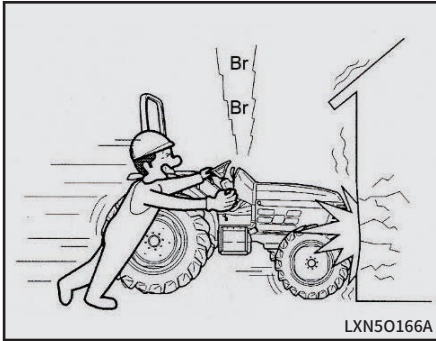

⚠ WARNING

Make sure that you are seated in the driver's seat with your seat belt fastened before starting engine:

- When starting the engine, make sure that you are seated in the driver's seat with your seat belt fastened and the safety inspection has been performed.

[Otherwise]

An unexpected accident may occur.

⚠ DANGER

Put tractor cover on only after tractor has cooled down:

- Put tractor cover on only after parts such as the engine and muffler cooled down.

[Otherwise]

There is a risk of fire.

⚠ DANGER

Do not open the radiator cap when the radiator is hot:

- Never open the radiator cap when the radiator is heated.

[Otherwise]

Hot water may splash, causing burns or damage.

PRECAUTION FOR PROLONGED STORAGE

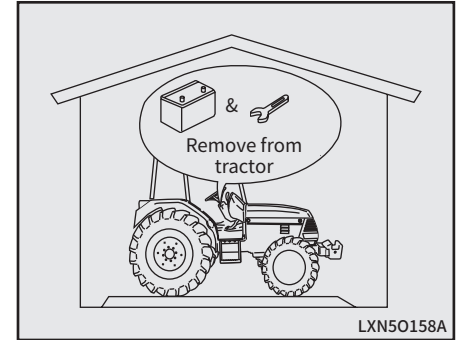
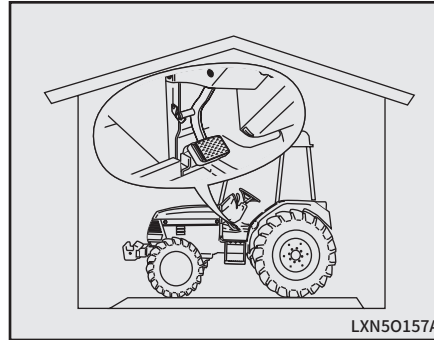
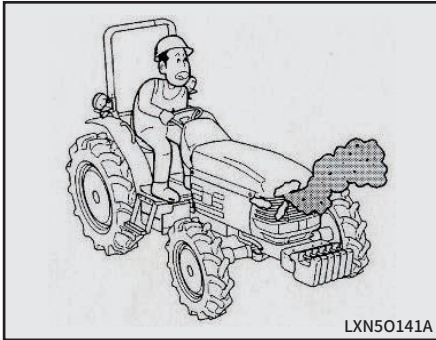

⚠ CAUTION

- Every day before operating the tractor, check if the electrical wiring is in contact with other parts, or if the insulation is peeling off, or the contact points are loose.

[Otherwise]

There is a danger of fire due to short circuit.

⚠ CAUTION

Disconnect the clutch when storing the tractor for a long time:

- When storing the tractor for a long period of time, make sure to put the clutch pedal in the “Disconnect” position.

[Otherwise]

The tractor may move and cause injury or an accident.

⚠ WARNING

Disconnect the Battery and the key when storing the tractor for a long period of time:

- When storing the tractor without use for a long period of time, remove the battery and keep the key in a safe place.

[Otherwise]

There is a risk of an accident.

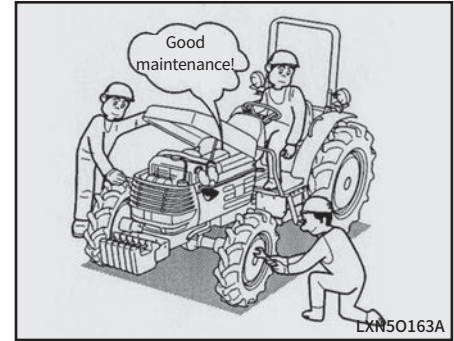
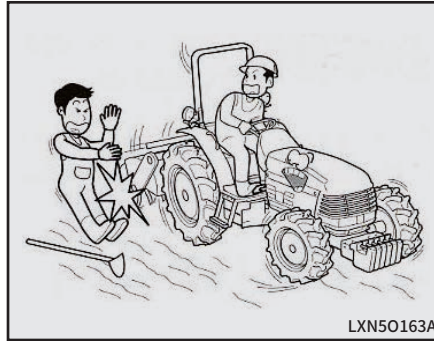
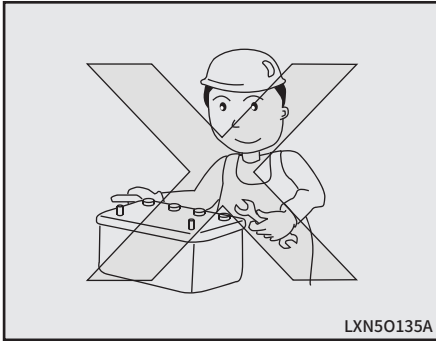

⚠ CAUTION

Be sure to connect battery cable on the right side and sequence:

- When connecting battery to tractor, connect + terminal first then - terminal but when disconnecting battery from tractor disconnect - terminal first then + terminal

[Otherwise]

There is a risk of fire or injury

⚠ WARNING

Confirm that the implement is down on the ground when starting the engine:

- When starting the engine, confirm that the position lever is on “Lowest” and that the auto rotary lever is on “Release”.

[Otherwise]

Implement may come down suddenly and cause an injury.

⚠ CAUTION

Maintain periodically:

- After using tractor, visit your local dealer for maintenance, such as oil change and filters.

[Otherwise]

There is a risk of accident due to poor maintenance.

PRECAUTIONS IN INCLINED AREA

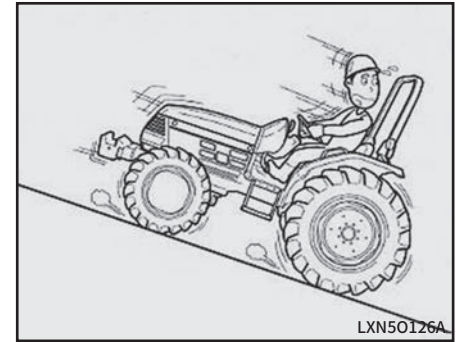
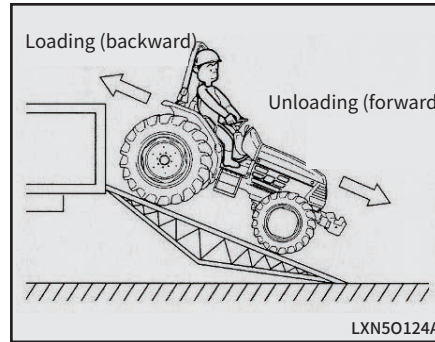
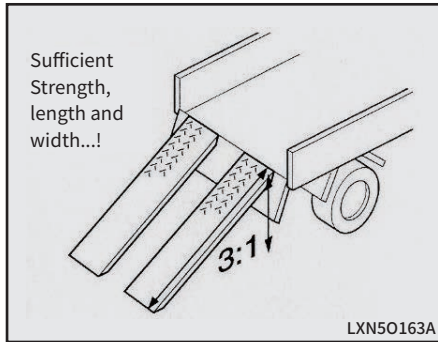

⚠ WARNING

Use loading ramps with proper slope & loading capacity:

- Loading or unloading must be done on a flat and safe place, the tractor engine switched off, and the parking brake engaged.
- The loading ramps must be non-slip and have sufficient strength, length, and width for the tractor.

[Otherwise]

The tractor may roll backward or fall, causing accident or injury.

⚠ WARNING

Move the tractor backward when loading, and forward when unloading:

- Move the tractor backward when loading it on the truck, and forward when unloading from the truck.

[Otherwise]

The tractor may roll backward or fall, causing accident or injury.

⚠ WARNING

- Be careful when driving on the loading ramps.

[Otherwise]

The tractor may roll backward or fall, causing accident or injury.

MAINTENANCE BEFORE OPERATING

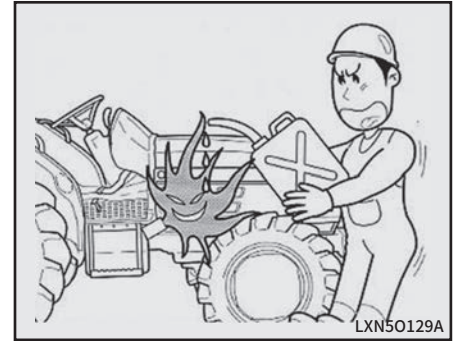
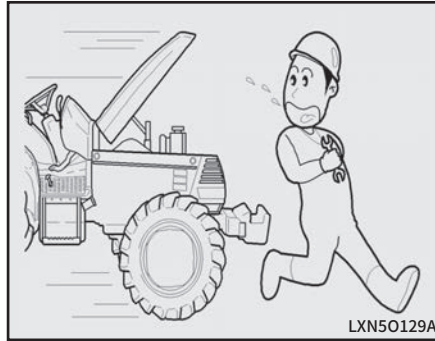
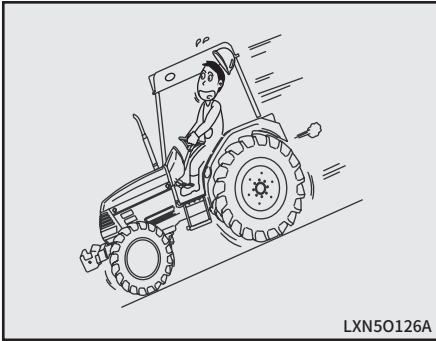

WARNING

Do not shift gears on slopes or on the loading ramps:

- When driving on slopes or on the loading ramps, select the proper gear and then do not shift the gear.

[Otherwise]

There is a risk of accident that the tractor may slip, roll, or overturn.

CAUTION

Stop the engine before maintenance:

- Turn engine off before performing any maintenance on the tractor.

[Otherwise]

There is a risk of injury.

DANGER

Fill the fuel tank only after the engine has cooled:

- Never add the fuel while the engine is running or hot.

[Otherwise]

The fuel may ignite and result in fire.

OTHERS



⚠ DANGER

Be careful when checking the battery:

- Avoid fire when checking or charging the battery.

[Otherwise]

You may get burnt due to ignition or explosion of the battery.

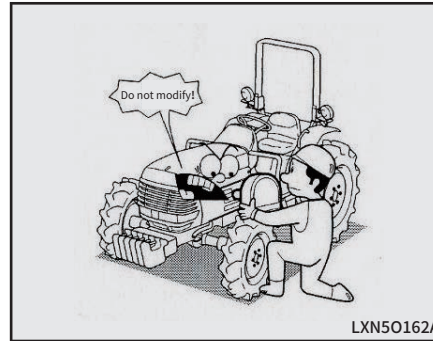

⚠ CAUTION

- Use only the genuine parts or other approved parts. Do not modify the tractor.

[Otherwise]

There is a danger of accident or injury or equipment failure. Please remember that the failure due to modification may not be covered by warranty.

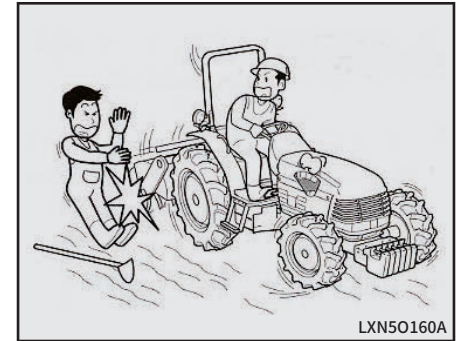

⚠ WARNING

Pay attention when turning with implement.

- Depending on implements, the overall length may become very long. Pay particular attention to people or objects nearby when making a turn.

[Otherwise]

There is a risk of personal injury or a damage of the implement.

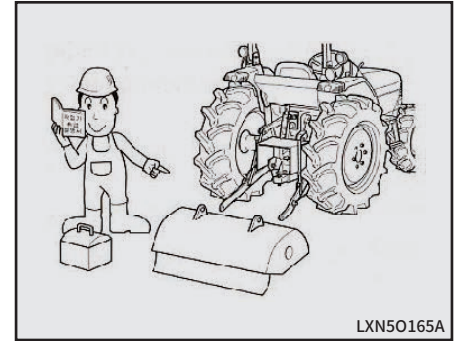
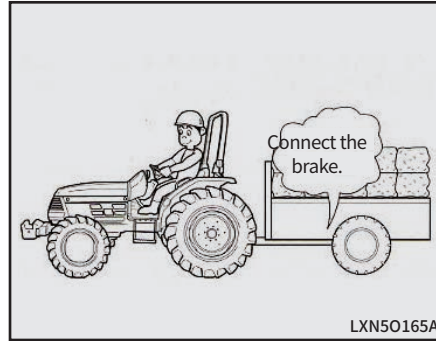
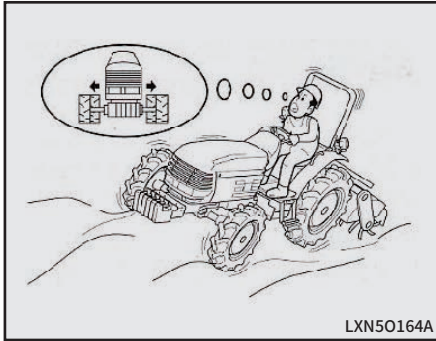

⚠ WARNING

- Move wheels to widest setting when working slope or when towing.

[Otherwise]

There is a danger of turning over.

⚠ WARNING

Use caution when towing a trailer:

- Link the brake of the trailer with the brake of the tractor. Do not shift gear when driving on a hill.

[Otherwise]

There is a risk of accident or injury.

⚠ WARNING

Follow the instruction manual when engaging an implement:

- When engaging an implement to the tractor, follow the instruction manual for the implement.

[Otherwise]

There is a risk of personal injury or damage to the tractor.

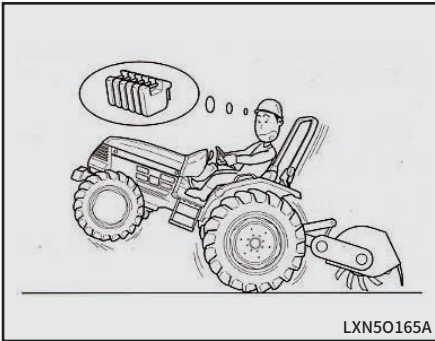

LXN50165A

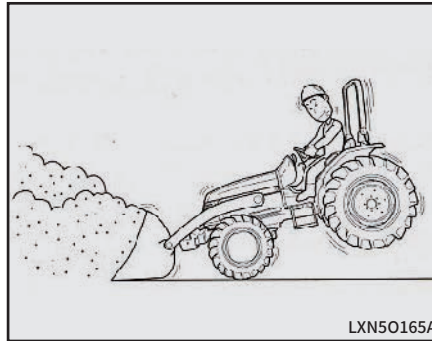

LXN50165A

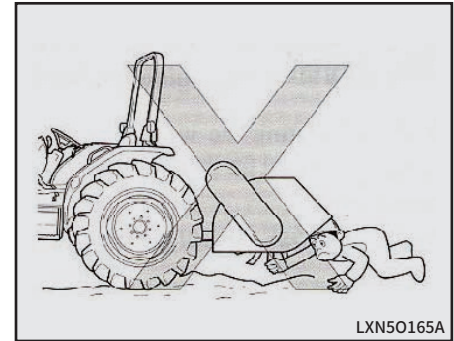

LXN50165A

⚠ WARNING

Balance a heavy implement with weights:

- When engaging a heavy implement or attachment, load the weight on the front to keep the balance of the tractor.

[Otherwise]

There is a danger of accident or injury due to loss of balance.

⚠ WARNING

Pay attention to the balance between the front and rear side during loader operation:

- During the loader operation, apply weights or an implement so as not to lose balance between the front and rear tractors.

[Otherwise]

There is a risk of overturning accident due to loss of balance.

⚠ WARNING

Do not put hands or feet under or near implement:

- Do not get under implement or put your feet under it.

[Otherwise]

The implement unit may fall down and there is a risk of injury.

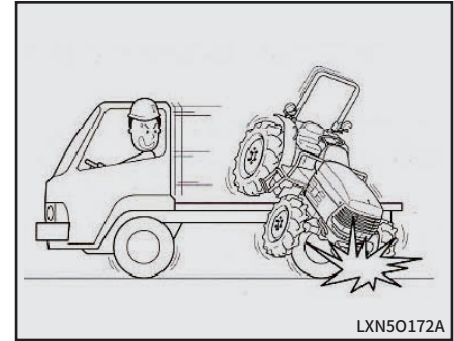
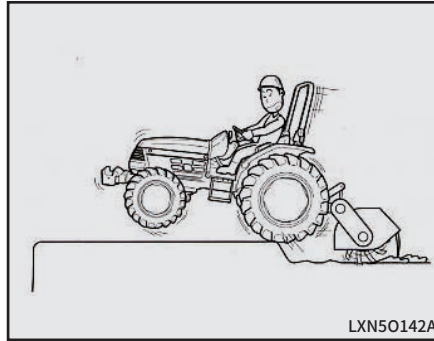
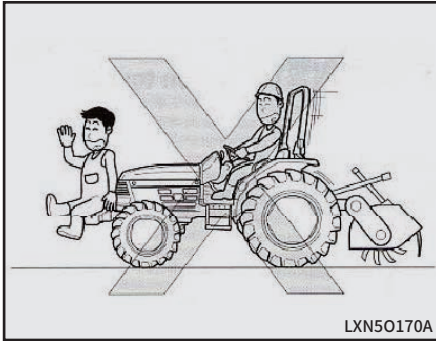

⚠ WARNING

Do not substitute balance weights with a person or anything else:

- Do not use a person on anything else in place of the balance weight. Use only recommended balance weight for the work.

[Otherwise]

There is a danger of accident or injury.

⚠ WARNING

Be careful of unexpected movement when using the rotary:

- When working with the rotary, put the rotary slowly on soft or rocky ground. The tractor may be pushed in an unexpected direction by the rotating force of the rotary.

[Otherwise]

There is a risk of accident or injury.

⚠ WARNING

Properly secure tractor during transports:

- When transporting the tractor, apply the parking brake with gear engaged and fasten the tractor to the truck securely with sufficient strength.

[Otherwise]

There is a risk of accident that the tractor may fall off the truck.

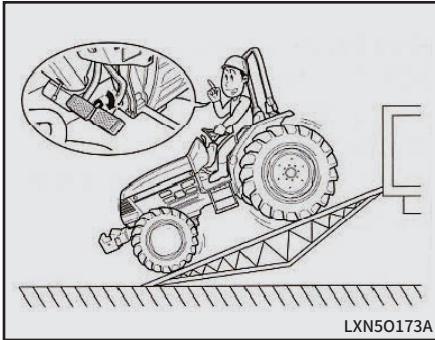

⚠ DANGER

- Make sure to connect the brakes on both sides when loading or unloading the tractor.

[Otherwise]

The tractor may overturn due to one-sided braking when the brake pedal is depressed in an emergency.

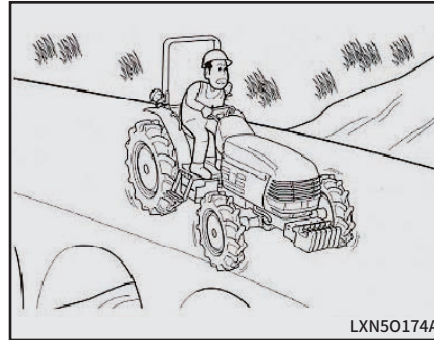

⚠ WARNING

- Make sure to release the differential gear lock when making a turn.

[Otherwise]

The tractor may not turn to the direction you want and cause an accident and damage the tractor.

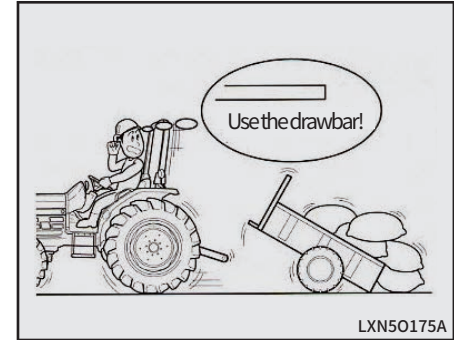

⚠ WARNING

Use the drawbar when towing:

- Make sure to use the drawbar when towing. Never tow anything with the top link or the lower link.

[Otherwise]

Tractor may turn over.

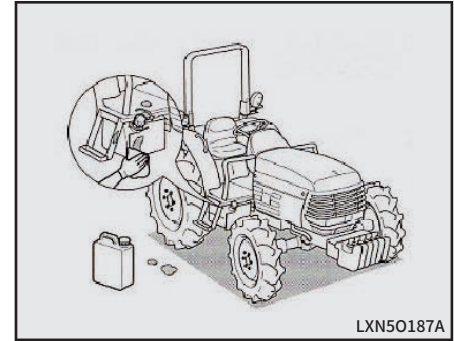
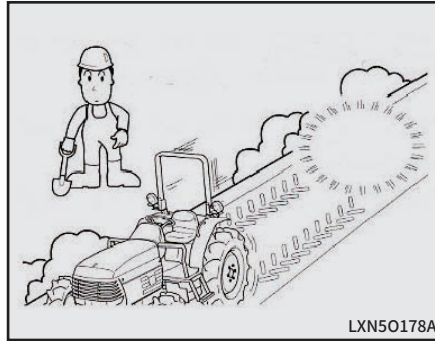
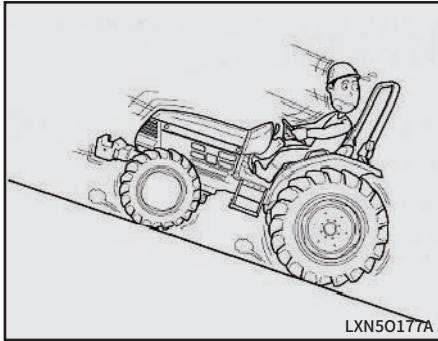

⚠ WARNING

Pay special attention when on a slope or loading ramps:

- Pay special attention to driving on a slope or the loading ramps.

[Otherwise]

There is a risk of accident that the tractor may slip, roll or overturn.

⚠ WARNING

Turn off engine in a flat area when leaving the tractor:

- When leaving the tractor, park the tractor on a flat and safe area, turn off the engine, and apply the parking brake. Also, let the implement rest on the ground.

[Otherwise]

The tractor may move and cause an accident.

⚠ DANGER

Remove spilled excess fuel before starting engine:

- After filling the fuel tank, close the fuel filler cap completely and wipe off the excess fuel thoroughly.

[Otherwise]

It may result in a fire accident or environmental pollution.

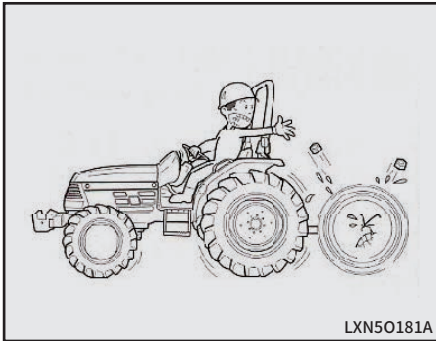

LXN50181A

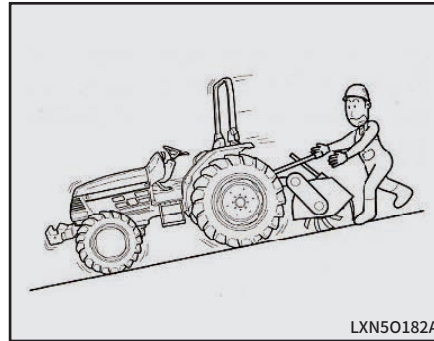

LXN50182A

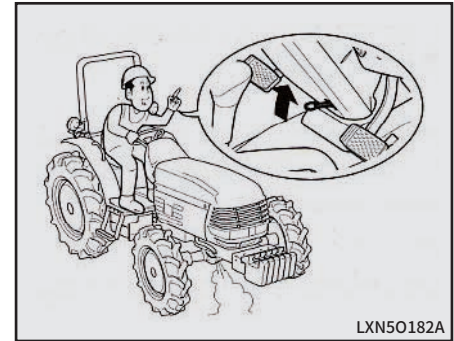

LXN50182A

⚠ WARNING

Be aware of the PTO RPM requirements for the implements:

- Do not use a low-revolution implement at high revolution. Be sure to check the designated PTO requirements for the implements.

[Otherwise]

The performance of the implement may not properly work and there is a risk of accident or injury or damage to the tractor.

⚠ WARNING

Only engage or disengage implements on flat, level area:

- Engage or disengage the implement on a flat and safe place. Supply proper lighting at all times and especially night.

[Otherwise]

There is a danger of accident.

⚠ WARNING

- Engage the parking brake while warming up engine.

[Otherwise]

The tractor may move and cause an accident or injury.

LOCATION OF SAFETY DECALS

Safety decals are provided to ensure safe operation. Keep the safety decals clean at all times and protect them from damage. In case of loss or damage, replace with a new decal.

10. TA00016518A

WARNING

BEFORE OPERATING TRACTOR:
 1. USE ON LEVEL, GRADE REDUCED MODELS.
 If working on a gradient, position tractor on right angles to the slope.
 2. ALWAYS SET PARKING BRAKE.
 Latching transmission in gear with the engine stopped will not prevent tractor from rolling.
 3. ALWAYS WEAR SEATBELT TO THE SEAT.
 Failure to comply to this warning may cause the operator to slip, and could cause injury or death.
 4. LOCK SAFETY SWITCH FOR INCREASED PROTECTION AND STOP THE ENGINE.



12530008

CAUTION

USE THESE SIGNALS TO INDICATE THE OPERATOR'S POSITION TO OTHER OPERATORS:
 1. When the tractor is in operation, the operator should use the hand signals to indicate the tractor's position to other operators.
 2. When the tractor is in operation, the operator should use the hand signals to indicate the tractor's position to other operators.
 3. When the tractor is in operation, the operator should use the hand signals to indicate the tractor's position to other operators.
 4. When the tractor is in operation, the operator should use the hand signals to indicate the tractor's position to other operators.
 5. When the tractor is in operation, the operator should use the hand signals to indicate the tractor's position to other operators.
 6. When the tractor is in operation, the operator should use the hand signals to indicate the tractor's position to other operators.
 7. When the tractor is in operation, the operator should use the hand signals to indicate the tractor's position to other operators.
 8. When the tractor is in operation, the operator should use the hand signals to indicate the tractor's position to other operators.
 9. When the tractor is in operation, the operator should use the hand signals to indicate the tractor's position to other operators.
 10. When the tractor is in operation, the operator should use the hand signals to indicate the tractor's position to other operators.
 11. When the tractor is in operation, the operator should use the hand signals to indicate the tractor's position to other operators.
 12. When the tractor is in operation, the operator should use the hand signals to indicate the tractor's position to other operators.



12530008

12. TZE5170000B4

WARNING

TO AVOID PERSONAL INJURY OR DEATH FROM ROLL-OVER, always use proper use of Roll-Over Protection Structure (ROPS) and seat belt to avoid a rollover. ROPS and seat belt are not a substitute for safe operation or safe practices. Safety rules, correct use of controls and proper use of ROPS are essential to safe operation. ALWAYS WEAR YOUR SEATBELT AND USE THE TRACTOR IN PROPER OPERATION. Observe and use the operator's seat belt. This decal is used together for further details, consult your Operator's Manual or your local dealer.



12530008

6. NTE5270000A4

WARNING

Keep the starter relay, away from water while cleaning. If not followed, damage can occur by starter motor.

NTE5270000A

4. TZE4190000B4

CAUTION

DIESEL ONLY TZE4190000B



9. NTE5150000C4

WARNING

Use seat belt.



NTE5150000C

8. NTE5210000C4

WARNING

DEATH OR INJURY MAY RESULT IF THE TRACTOR ROLLS OVER WITH THE ROPS IN THE FOLDED DOWN POSITION. OPERATE THIS TRACTOR WITH THE ROPS FOLDED DOWN ONLY WHEN NECESSARY.



5. TZE5130000B4

CAUTION



12530008

7. TZE5110000B4

DANGER

Start only from seat in park or neutral. Starting in gear kills.



12530008

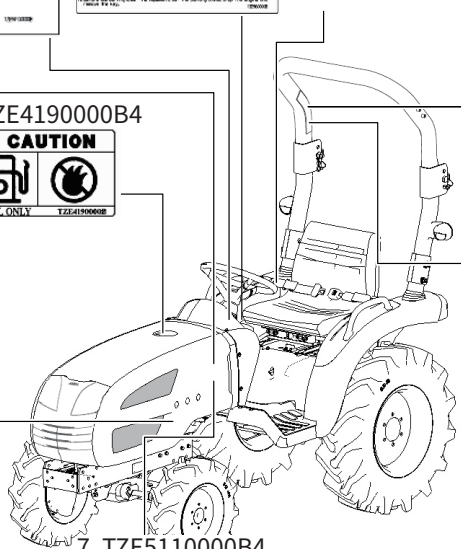

No	Part code	Part description
4	TZE4190000B4	Label, Filler Caution
5	TZE5130000B4	Label, Muffler
6	NTE5270000A4	Label, Start Caution
7	TZE5110000B4	Label, Start Caution
8	NTE5210000C4	Label, Pto
9	NTE5150000C4	Label, Drawbar
10	TA00016518A	Label, Safety
11	TA00016517A	Label, Safety
12	TZE5170000B4	Label, Rops Warning

No	Part code	Part description
1	TZE5180000B4	Label, Fan Warning
2	TZE4300000B4	Label, Pto Caution
3	NTE5220000C4	Label, Safety

3. NTE5220000C4

WARNING
 This structure's protective capability may be impaired by structure damage, over-turn, or alterations. If any of these conditions occur, the structure must be replaced.
NTE5220000C4

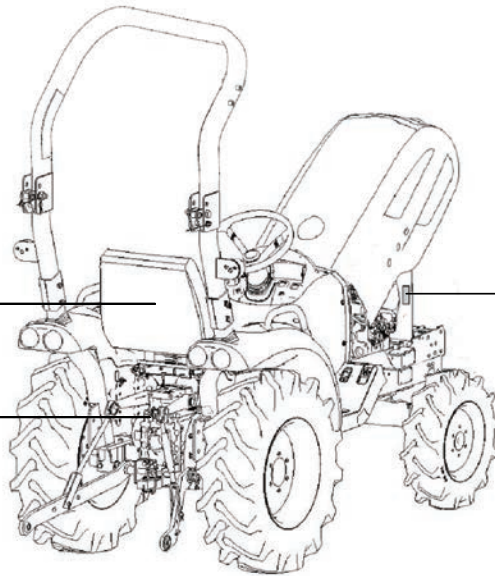

WARNING
TO AVOID PERSONAL INJURY:
 1. Keep PTO shield in place at all times.
 2. Do not operate the PTO at speeds faster than the speed recommended by the implement manufacturer.
 3. For tractors with PTO-driven implements set driver or riding position, see operator's manual.
 4. Keep hands, feet and clothing away.
TZE4300000B4

2. TZE4300000B4



1. TZE5180000B4

MEMO

A series of 20 horizontal dotted lines for writing.

2. ABOUT WARRANTY

WARRANTY.....	2-2
TROUBLE SHOOTING	2-2

WARRANTY

You will need the “Warranty paper work” when your tractor requires warranty service. Read it and keep in a safe place.

TROUBLE SHOOTING

In case of mechanical trouble, refer to “Trouble shooting” on end of this manual. If the problem cannot be corrected, please contact your nearest authorized dealer.

<Information you will need when contacting the dealer for service>

Type of model and tractor serial number.

In case of engine, the engine serial number.

Circumstances of breakdown. (what kind of work, gear position, etc.)

Amount of work done. (square footage or number of hours)

Other information with as much detail as possible about the circumstance of the breakdown.

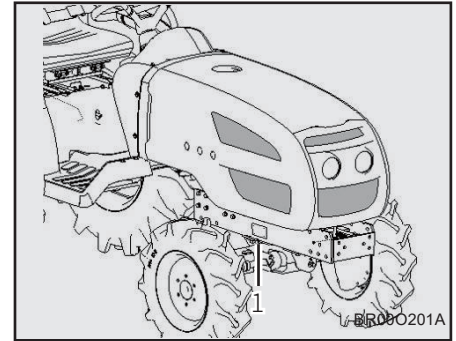

(1) Tractor Serial Number.

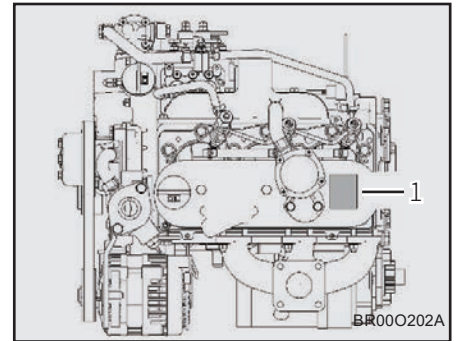

(1) Engine Serial Number

3. OVERVIEW OF THE TRACTOR

EXTERIOR VIEW 3-2

EXTERIOR VIEW

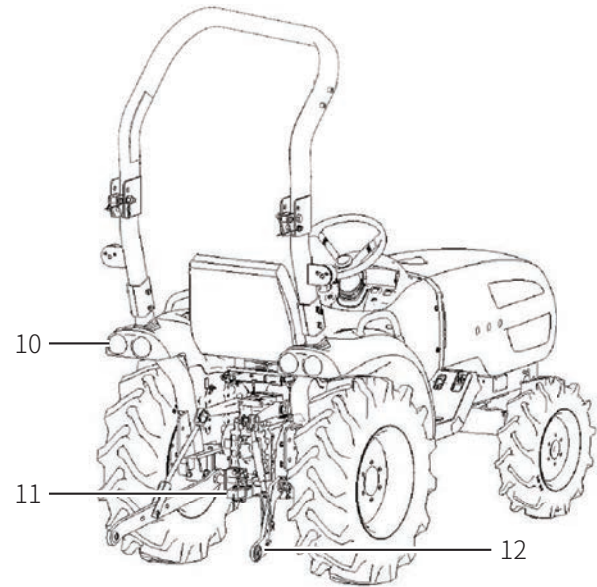
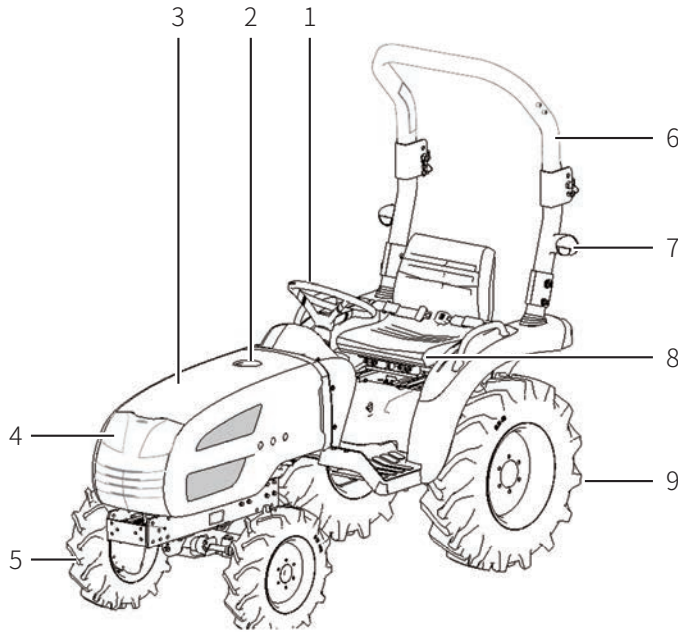

- (1) Steering Wheel
- (2) Fuel Tank
- (3) Hood
- (4) Head Lamp

- (5) Front Tire
- (6) ROPS
- (7) Turn Signal Lamp
- (8) Seat

- (9) Rear Tire
- (10) Combination Lamp
- (11) Drawbar
- (12) Lower Link

BR000301B

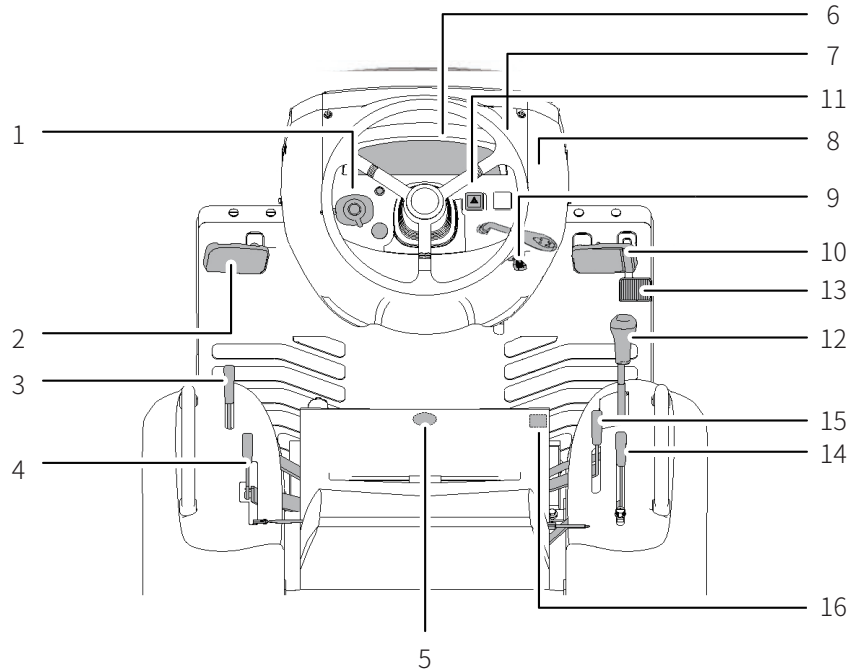

(1) Combination S/W
 (2) Clutch Pedal
 (3) Range Shift Lever
 (4) PTO Lever

(5) Flow Control Valve
 (6) Instrument Panel
 (7) Steering Wheel
 (8) Throttle Lever

(9) Main Key Switch
 (10) Brake Pedal
 (11) Hazard Lamp S/W
 (12) Main Shift Lever

(13) Accelerator Pedal
 (14) Position Lever
 (15) MFWD Lever
 (16) Differential Lock Pedal

MEMO

A series of 20 horizontal dotted lines for writing.

4. FUNCTIONS

SWITCHES AND LEVERS	4-2	PEDALS	4-9
MAIN KEY SWITCH.....	4-2	CLUTCH PEDAL	4-9
THROTTLE LEVER	4-3	BRAKE PEDAL.....	4-10
ACCELERATOR PEDAL.....	4-3	DIFFERENTIAL LOCK PEDAL	4-10
TURN SIGNAL S/W	4-4	F-R HST DRIVE PEDAL	4-11
HEAD LAMP & HORN S/W	4-4	CRUISE CONTROL UNIT.....	4-12
LAMP SWITCH	4-4		
INSTRUMENT PANEL.....	4-5	LEVER OPERATION (R)	4-13
TACHOMETER	4-5	MAIN GEAR SHIFT LEVER.....	4-13
ENGINE HOUR METER	4-6	POSITION CONTROL LEVER	4-14
PTO POSITION	4-6	MFWD LEVER.....	4-14
PRE-HEAT LAMP.....	4-6		
BATTERY CHARGE LAMP.....	4-7	LEVER OPERATION (L).....	4-15
ENGINE OIL PRESSURE LAMP	4-7	RANGE SHIFT LEVER	4-15
FUEL GAUGE.....	4-7	PTO SHIFT LEVER.....	4-16
WATER TEMP GAUGE	4-8	FLOW CONTROL VALVE.....	4-17
HEAD LAMP (HIGH BEAM).....	4-8		
		OTHERS	4-17
		SEAT BELT	4-17
		TAIL LAMP	4-18
		BRAKE LAMP	4-19

SWITCHES AND LEVERS

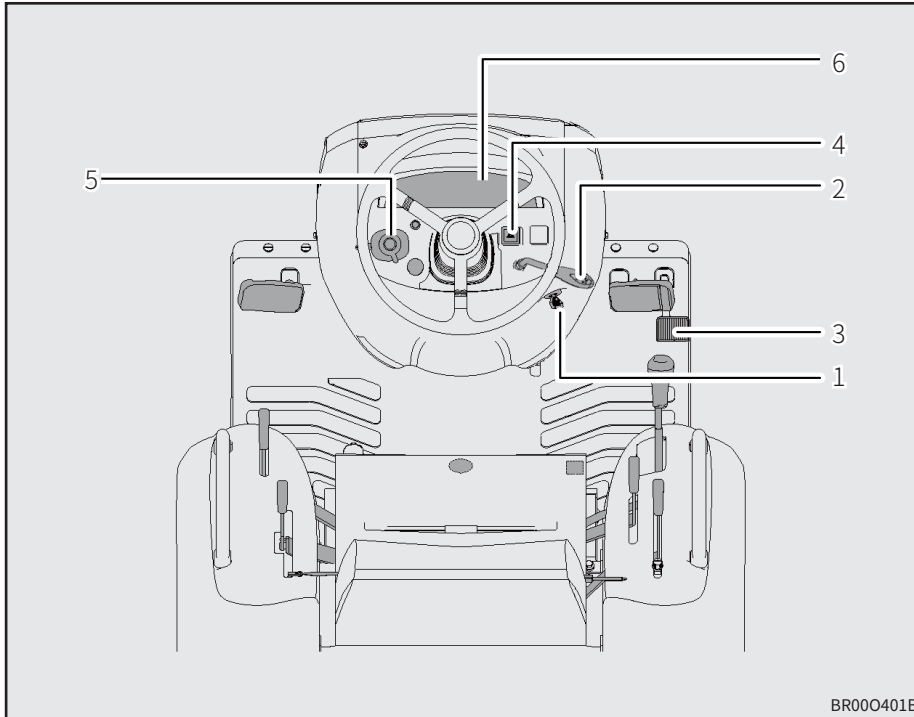

(1) Main Key Switch
(2) Throttle Lever
(3) Accelerator Pedal

(4) Hazard Lamp Switch
(5) Combination Switch
(6) Instrument Panel

MAIN KEY SWITCH

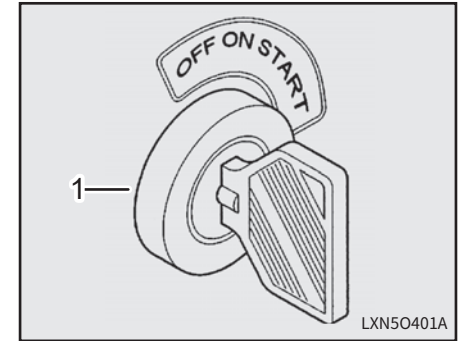

(1) Main Key Switch

It is used to start the engine.

- "OFF"

The engine is stopped, and current does not flow. (The key can be taken out)

- "ON"

Electric current flows to the switched of all electrical parts. If the engine is stopped, the engine oil pressure lamp and the battery charge pilot lamp are lit.

Depending on the outside temperature, the thermostat pilot lamp may also be lit.

- "START"

Starting motor turns and the engine is started.

Once the engine is started, take your hand off the key.

The key will return to the "ON" position automatically and the engine will keep running.

Turn engine off before performing any maintenance on tractor.

CAUTION

- When the tractor is not in use, take out the key and keep it in a safe place.

[Otherwise]

Children may start the tractor and cause an accident.

ACCELERATOR LEVER

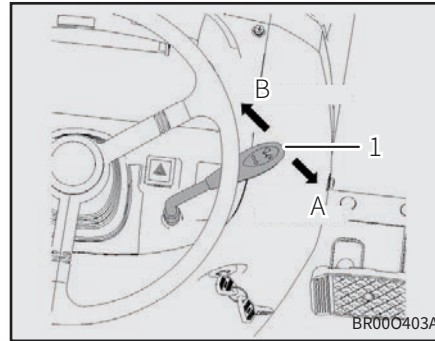

(1) Throttle Lever

(A) Increase

(B) Decrease

It is used to make the engine run faster or slower. It is also used when working at a constant speed.

ACCELERATOR PEDAL

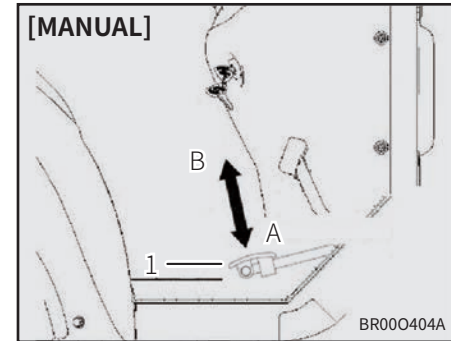

(1) Accelerator Pedal

(A) Increase

(B) Decrease

It is used to make the engine run faster or slower. It is usually used when driving on a road. (Manual transmission only)

TURN SIGNAL S/W

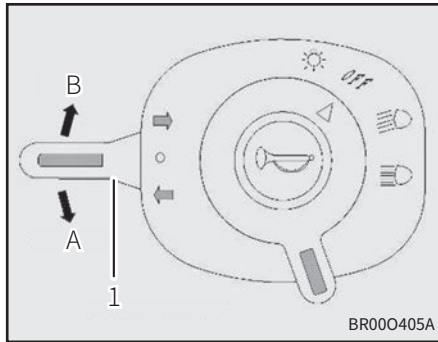

(1) Turn Signal Switch
(A) Left (B) Right

With the key switch in the “ON” position, turn the direction indicator switch to the right to turn on the direction indicator lamp in the right side, and turn the indicator switch to the left to turn on the lamp on the left.

HEAD LAMP & HORN S/W

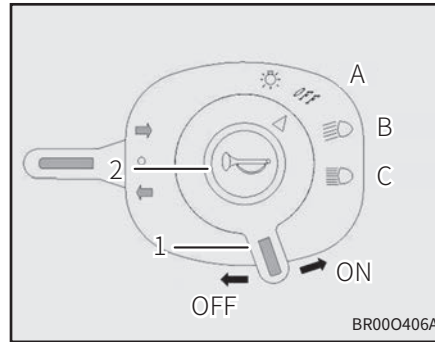

(1) Head Lamp Switch (2) Horn Switch
(A) OFF (B) Low beam
(C) High Beam

► HEAD LAMP S/W

With the main switch in the “ON” position, turn the light switch one click to the right for high beam and two clicks to the right for low beam.

► HORN S/W

With the main switch in the “ON” position, press the horn button to sound the horn.

HAZARD LAMP SWITCH

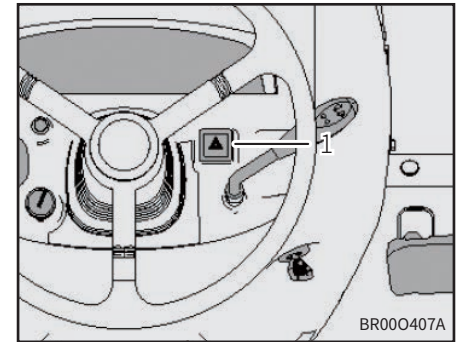

(1) Hazard Lamp Switch

Used to prevent accidents in an emergency. Activate by pressing switch to warn other vehicles.

Hazard lamp operates regardless of main switch and every turn signal lamp will cease at once. Press once again to cancel.

INSTRUMENT PANEL

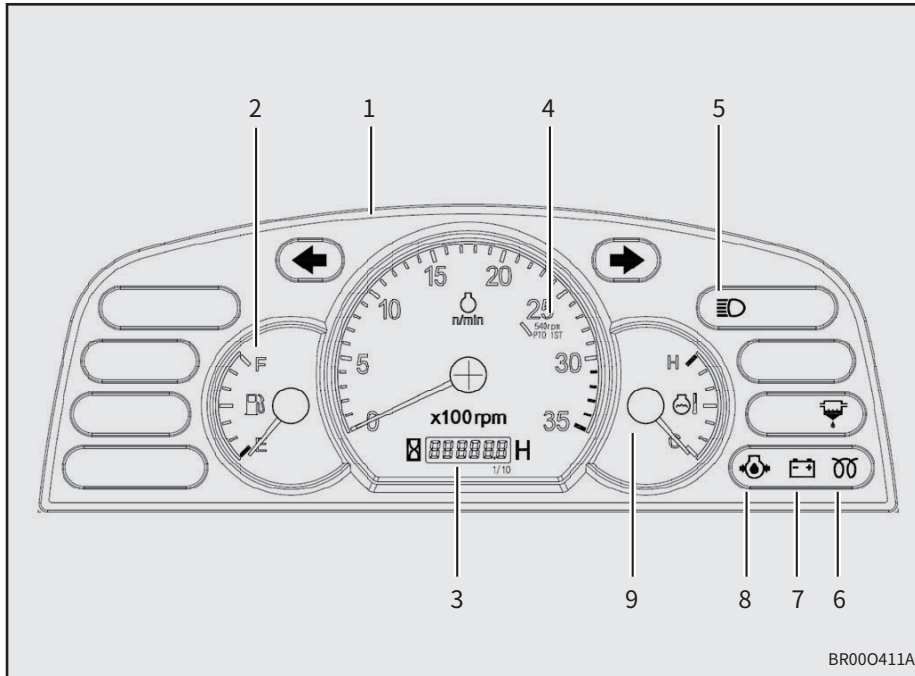

- (1) Meter Panel
- (2) Fuel Gauge
- (3) Hour Meter
- (4) PTO Position
- (5) Head lamp High beam

- (6) Pre-heat Lamp
- (7) Battery Charge Lamp
- (8) Engine oil pressure lamp
- (9) Water Temp Gauge

TACHOMETER

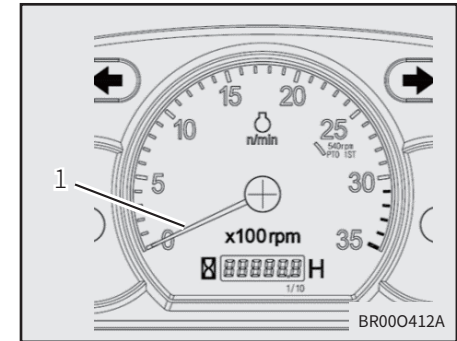

(1) Engine Rpm Indicator

The needle indicates the number of engine RPM.

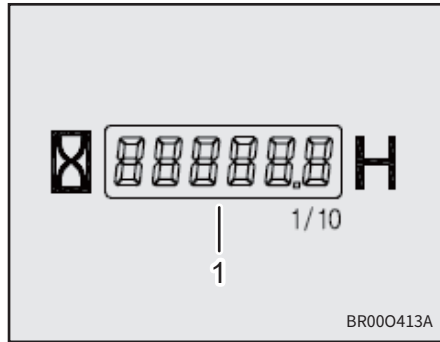
HOURL METER*(1) Engine Hour Meter*

It indicates the tractor's running hours. By multiplying the digit in the far right position by 6, you will get the time in minute.

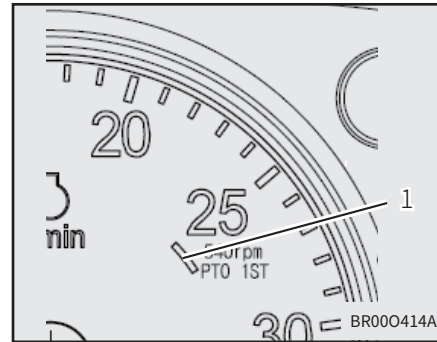
PTO POSITION*(1) PTO Position*

It Indicates the position 2,600 rpm where PTO revolutions achieve 540, and 1,000 rpm. And 1,700 rpm position where PTO revolutions achieve 540E.

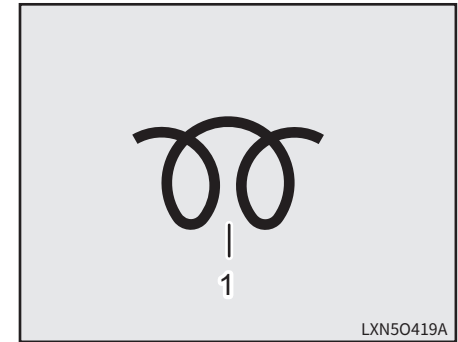
PRE-HEAT LAMP*(1) PRE-HEAT Lamp*

Lamp will light on/off depending on temperature of engine coolant when main key switch is turned on.

Lamp will be turned off when heater coil is heated. Start engine after this lamp is turned off.

It is difficult to start engine in winter when starting engine before warm up lamp is turned off. It also causes early discharge of battery.

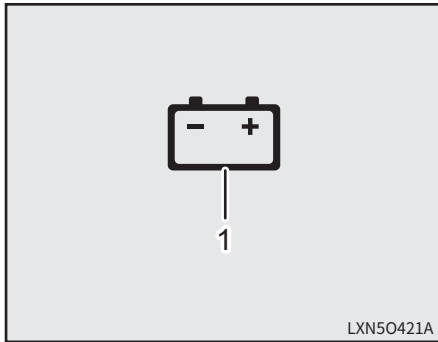
BATTERY CHARGE LAMP*(1) Battery Charge Lamp*

It will be turned on when the key switch is put into the “ON” position, and will be turned off when the battery starts being charged after engine is started and the engine revolution increases. The battery will not be charged with the engine below 1,000 rpm. (The rpm should be 1,500 rpm or higher)

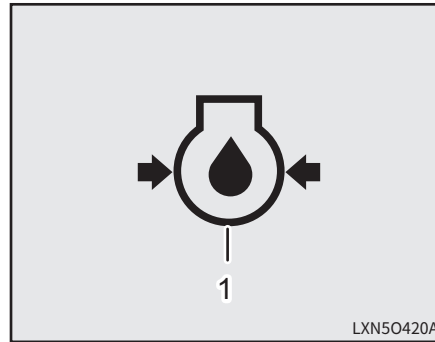
ENGINE OIL PRESSURE LAMP*(1) Engine Oil Pressure Lamp*

Lamp will come on when the ignition switch is put into the “ON” position. It will turn off when the engine is started.

If this lamp comes on while the engine is running, it indicates a problem in the engine oil system. Stop the engine immediately and check for problems.

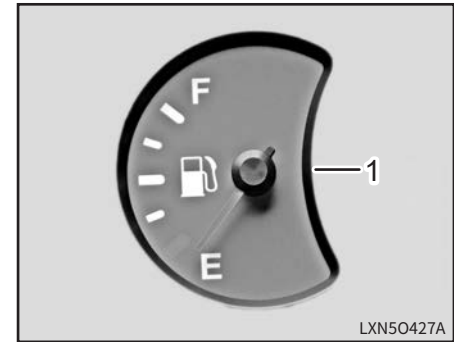
FUEL GAUGE*(1) Fuel Gauge*

The needle indicates the quantity of fuel remaining in the tank. If the needle is in the red zone, refill immediately.

WATER TEMP GAUGE

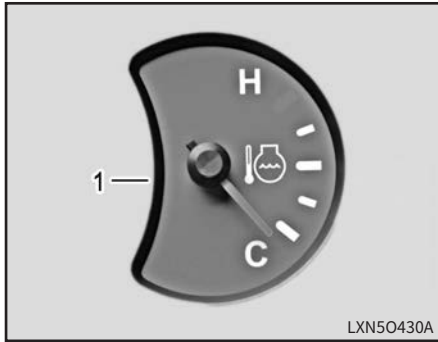

(1) Water Temp Gauge

The needle indicates the temperature of the engine coolant during running. If the needle is in the red zone, stop running the engine and check for problems.

HEAD LAMP (HIGH BEAM)

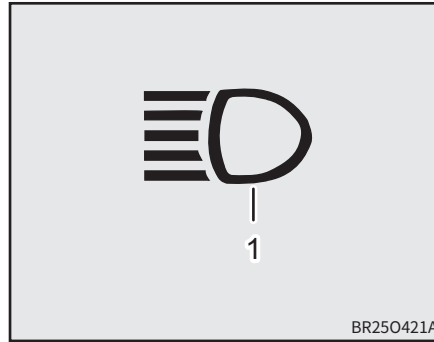

(1) High Beam Head Lamp

Indicates the head lamps beam's position. It will come on when the head lamps are on High beam. On the contrary, if the head lamps are in the low beam, this indicator will not be lit.

PEDALS

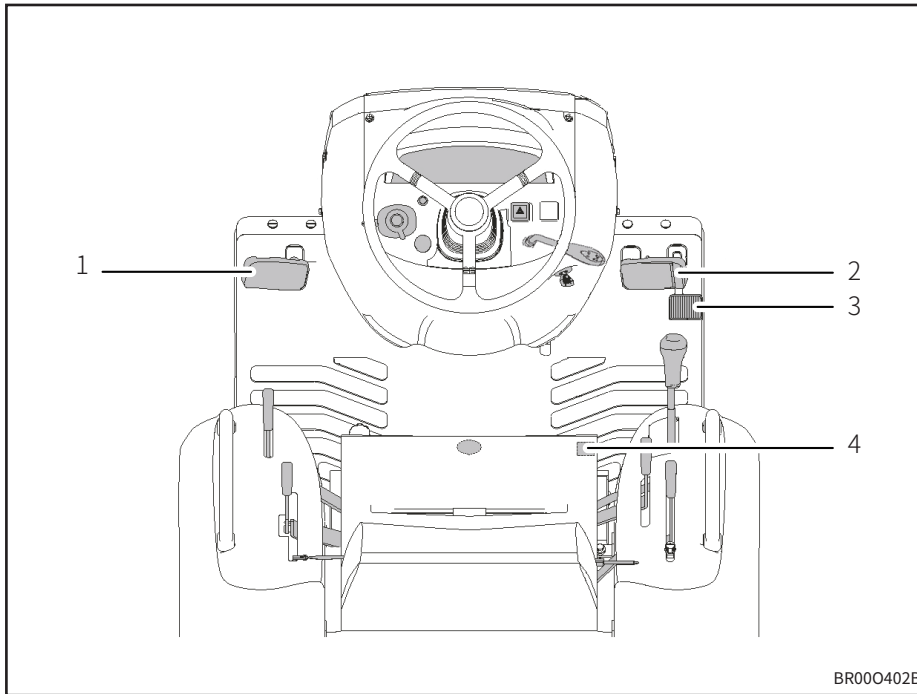

BR000402B

(1) Clutch Pedal
(2) Brake Pedal

(3) Accelerator Pedal
(4) Differential Lock Pedal

CLUTCH PEDAL

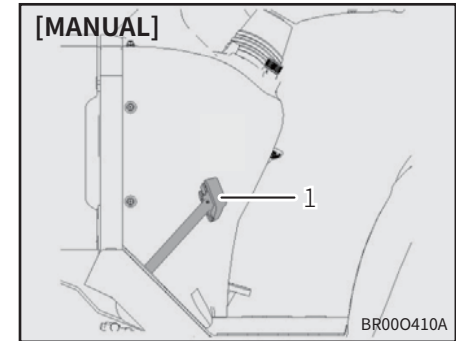

BR000410A

(1) Clutch Pedal

It is used to transmit the engine power. (Manual transmission only)

BRAKE PEDAL

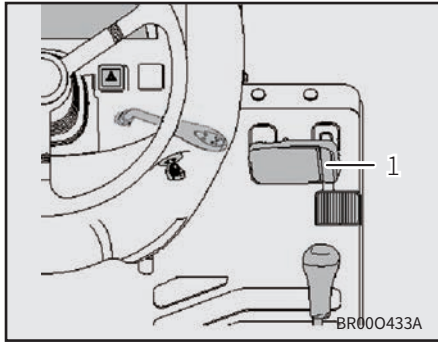

(1) Brake Pedal

Brake pedals are independent of each other and can be used for making a small turn on the pavement. Depressing the brake pedal on the side to which to make a turn, the rear wheel on that side is stopped and the tractor can make a small turn.

WARNING

- Make sure to connect the brake pedals with the brake pedal coupler when driving on a road.

[Otherwise]

There is a risk of abrupt turning or overturning due to one-sided braking.

DIFFERENTIAL LOCK PEDAL

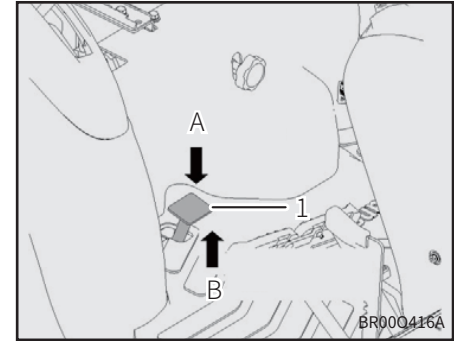

(1) Differential Lock Pedal

- (A) Releasing the pedal, disengage the diff lock
 (B) Depressing the pedal, engage the diff lock

It is used to transmit the same power to both rear wheels and serves to prevent slipping when one of the rear wheels is idling.

WARNING

- Release the differential gear lock when making a turn.

[Otherwise]

The tractor may not turn in the direction you want and cause an accident.

F-R HST DRIVE PEDAL

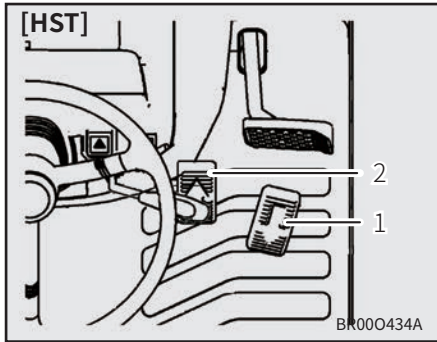

- (1) Backward HST Pedal
(2) Forward HST Pedal

<Forward Pedal>

Depress the forward Pedal with your foot to move Forward.

<Backward Pedal>

Depress the backward Pedal with your foot to move backward.

WARNING

To avoid personal injury:

- Do not operate if tractor moves on level ground with foot off Hst pedal.

CRUISE CONTROL UNIT

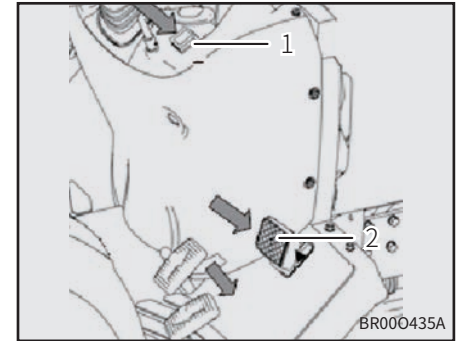

- (1) Cruise Switch (2) Brake Pedal

The Cruise Control unit is designed for tractor operating efficiency and operator comfort. This unit will provide a constant forward operating speed by electronically holding the speed control pedal at a selected position.

<To engage Cruise control Unit>

1. Accelerate speed to desired level using Forward Pedal, and push the Cruise switch: Green lamp “ON”
2. Release Forward Pedal and desired speed will be maintained.

<To disengage Cruise control Unit>

1. Push the Cruise switch: Green lamp “Off”.
2. Depress both Brake Pedal.

Cruise Control Unit do not operate in reverse.

LEVER OPERATION (R)

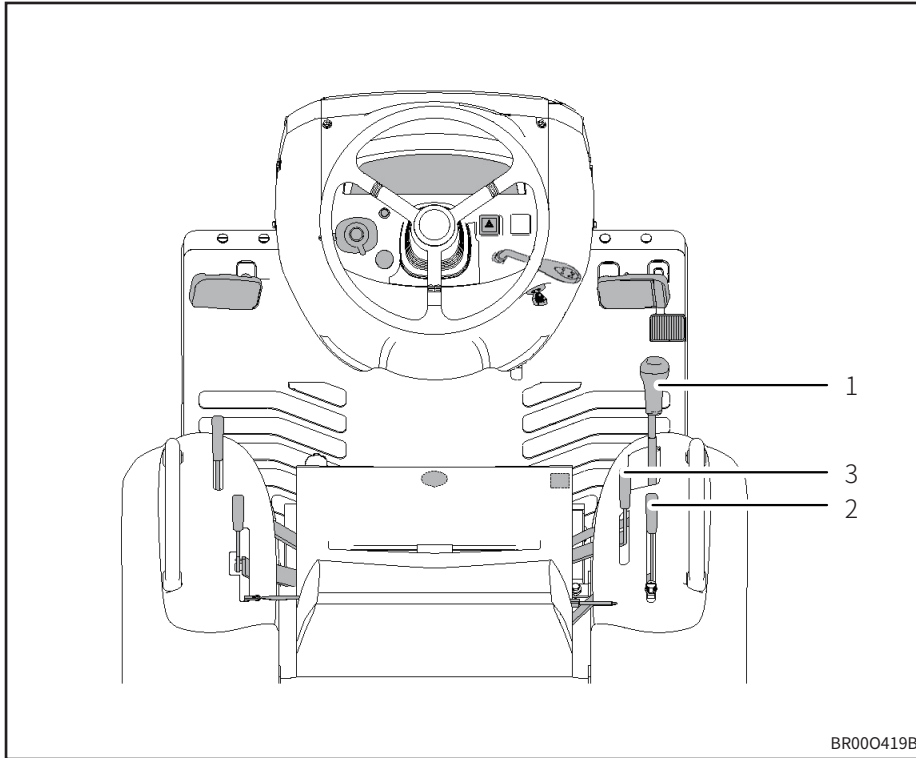

BR000419B

(1) Main Gear Shift Lever
(2) Position Control Lever

(3) MFWD Lever

MAIN GEAR SHIFT LEVER

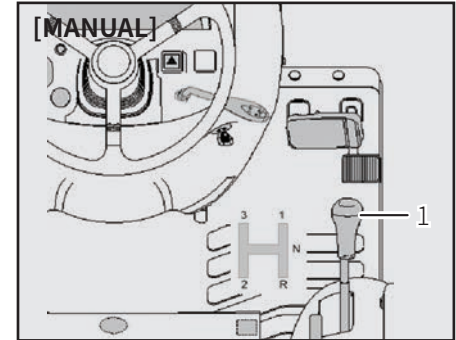

(1) Main Gear Shift Lever

The gear shifts in four levels. When shifting the gears depress the clutch fully. (Manual transmission only)

⚠ CAUTION

- Do not shift while driving.
[Otherwise] The gear may be damaged.

POSITION CONTROL LEVER

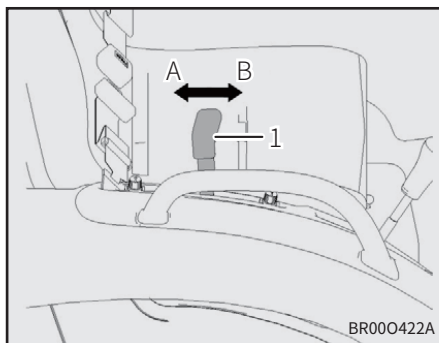

(1) Position Control Lever
(A) Raise (B) Lower

When lowering the implement, set the position control lever, and the implement will go down to the set position.

It is used to keep the implement constantly at a certain position. When the lift lamp is on, the implement cannot be lowered with position control lever. A stopper is used to fix the position control lever in the “UP” position while driving on a road.

WARNING

- Confirm that no one or a foot is under the implement before operating the system.

[Otherwise]
There is a risk of injury.

MFWD LEVER

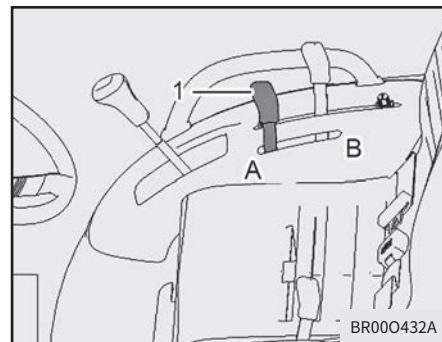

(1) MFWD Lever
(A) Connect (B) Disconnect

It is used to shift between 2-wheel drive and 4 wheel drive. Depress clutch pedal or stop machine when shifting the lever.

CAUTION

- Do not shift while driving.
- [Otherwise] The gear may be damaged.

LEVER OPERATION (L)

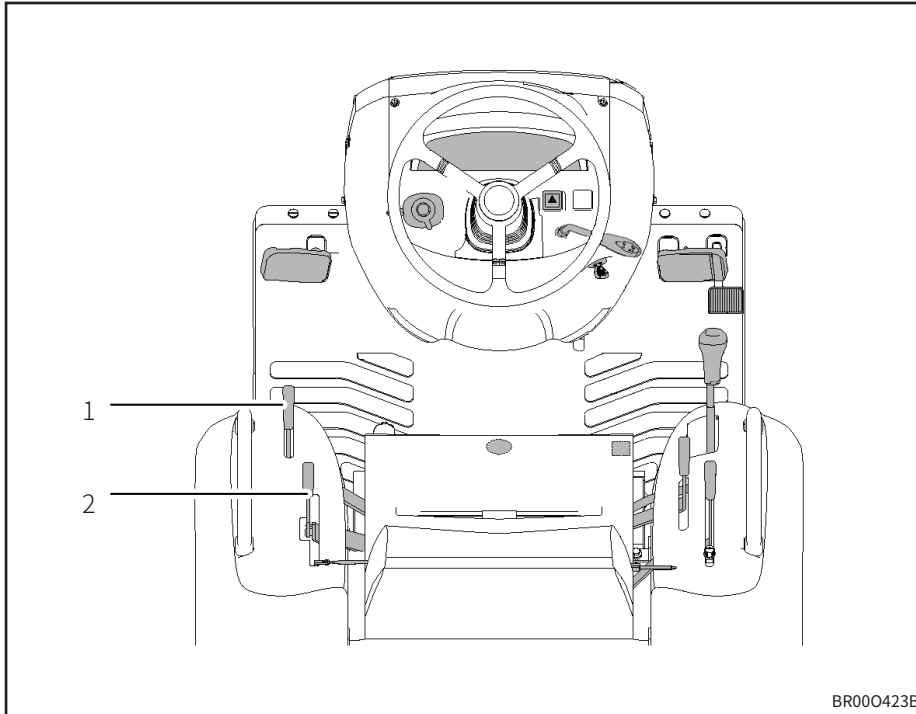

BR000423B

(1) Range Gear Shift Lever

(2) PTO Shift Lever

2400 RANGE SHIFT LEVER

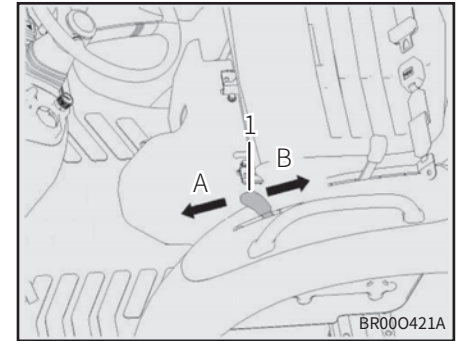

BR000421A

(1) 2400 Range Shift Lever
(A) High (B) Low

The range gear is shifted in three stages, in combination with the main gear shifting. When shifting the range gear, depress clutch fully.

CAUTION

- Do not shift while driving.
[Otherwise] The gear may be damaged.

2510 RANGE SHIFT LEVER

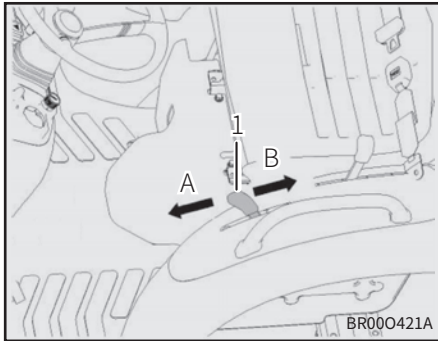

(1) 2510 Range Shift Lever
 (A) High, Middle (B) Low

The range gear is shifted in four stages, in combination with the main gear shifting. When shifting the range gear, depress clutch fully.

⚠ CAUTION

- Do not shift while driving.
 [Otherwise] The gear may be damaged.

PTO SHIFT LEVER

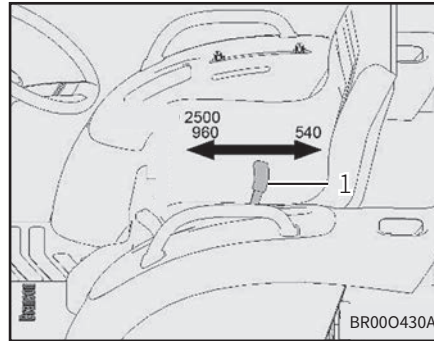

(1) PTO Shift Lever

The revolution of the PTO shaft can be shifted in two stages. (1st Rear 540 rpm : 2nd Rear 960 rpm - Mid 2500 rpm)
 When shifting level, press clutch pedal deeply.

⚠ CAUTION

- Observe the PTO speed designated on the work unit.
- Otherwise, the work unit may be damaged and cause an accident.

⚠ CAUTION

- Do not shift while driving.
 [Otherwise] The gear may be damaged.

FLOW CONTROL VALVE

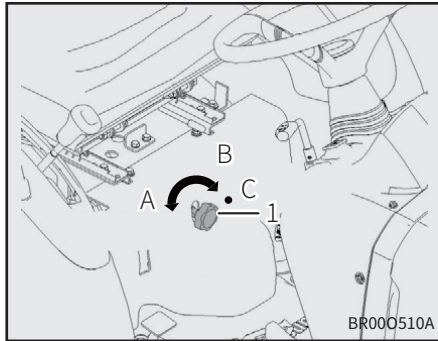

(1) Flow Control Valve
 (A) Fast (B) Slow
 (C) Stop

It is used to regulate the lowering speed of the work unit (slow return function). Also, if you wind the valve fully to the right, the hydraulic pressure to the device raising the work unit is stopped.

OTHERS SEAT BELT

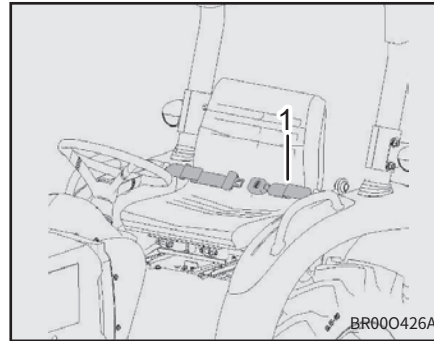

(1) Seat Belt

⚠ WARNING

[Otherwise]

There is a risk of death or injury if the tractor turns over. Adjust the seat to the driver and keep the upper body upright. Wrap the seat belt around the waist and insert it into the buckle until the clicking sound is heard. When releasing the seat belt, use the “PRESS” button.

⚠ WARNING

- Do not wear the seat belt when the safety frame is folded down. With the frame folded down, it does not provide safety.
- When operating the tractor, make sure to keep the safety frame in the upright position and wear the seat belt.

TAIL LAMP

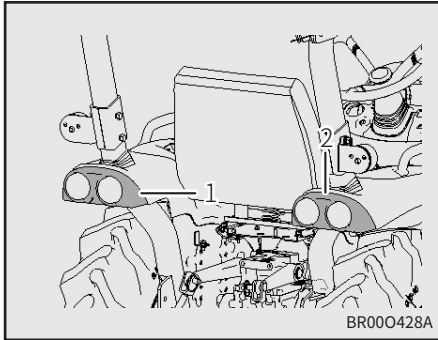

(1) Tail Lamp (L)

(2) Tail Lamp (R)

It is connected with the head lamp and is turned on when the head lamp is turned on.

BRAKE LAMP

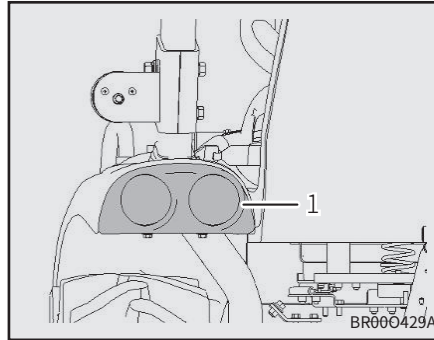

(1) Brake Lamp

It is turned on when the brake pedal is depressed.

5. OPERATION & WORK

CHECKING BEFORE OPERATION	5-2
STARTING / STOPPING THE ENGINE	5-9
TO START THE ENGINE	5-10
TO STOP THE ENGINE.....	5-12
TO RAISE OR LOWER THE IMPLEMENT	5-12
ADJUSTING THE LOWERING SPEED OF THE IMPLEMENT	5-13
DRIVING ON THE ROAD	5-13
DRIVING ON THE SLOPE	5-14
ENTERING AND LEAVING THE PAVEMENT	5-15
TURNING ON THE PAVEMENT	5-15
DIFFERENTIAL LOCK	5-16
TRACTOR LOADING /UNLOADING.....	5-17
INSTALLING 3POINT LINK	5-18

PRECAUTIONS FOR CONNECTING THE IMPLEMENT	5-19
AUX. HYDRAULICS	5-20
ADJUSTING WHEEL TREAD	5-21
POWER STEERING	5-21
TOWING INSTRUCTIONS	5-22
PTO SPECIFICATIONS & PRECAUTIONS	5-22
LOADER OPERATION.....	5-23
CARRYING THE LOAD	5-24
HANDLING LARGE & HEAVY OBJECTS	5-25
ROPS FOLDING METHOD.....	5-26
HOW TO FOLD DOWN THE ROPS	5-26

CHECKING BEFORE OPERATION

DANGER

- Do not provide illumination with a lit cigarette or a lighter when fueling.
- Never fill the fuel tank while the engine is running or hot.
- After filling the fuel tank, close the fuel filler cap completely and wipe off the excess fuel thoroughly.

If the fuel hoses are damaged, fuel will leak. Make sure that you check for any leakage.

WARNING

- Perform the maintenance on a flat and safe location that will keep the tractor in place and will not cause a risk to people passing by. Before carrying out the maintenance, place blocks at the front tires to prevent movement.

[Otherwise]

An unexpected accident may occur, such as overturning of the tractor.

- When going under the implement, fully close the slow/stop valve.

[Otherwise]

There is a risk of injury due to implement falling.

CAUTION

- Stop the engine during checking, maintenance, or repair
- Carry out the maintenance work after heated area such as the muffler or the engine have fully cooled down.

[Otherwise]

There is risk of burn.

- After detaching the covers for checking or maintenance, make sure to put them back in their place.

[Otherwise]

There is a risk that you may get entangled in the tractor or get injured.

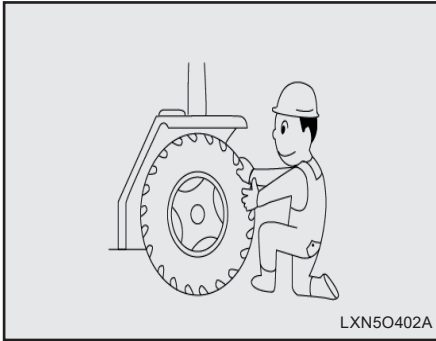

2. Check around the tractor.
 - Deformation, damage or stains.
 - Tire pressure and abrasion.
 - Damage to the tractor, or loosened bolts.
 - Loosening of wheel bolts.
 - Fuel quantity, fuel leaks, or damage to the fuel hose.



To ensure a safe and comfortable operation, please carry out the routine check-up everyday before starting work. Correct any problem immediately, and also check for problems after work. This checking should be done in the following sequence.

1. Check the suspicious parts of the previous day.
 - Check the parts that you thought were not normal during the work of previous day.

3. Open the engine hood.
 - Engine oil level, contamination, or leakage.

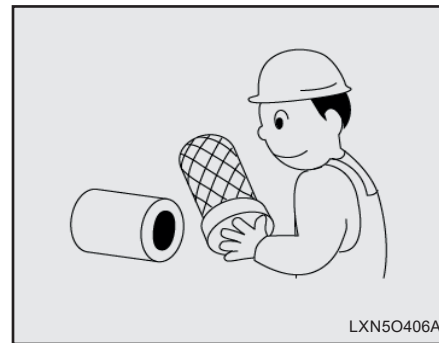
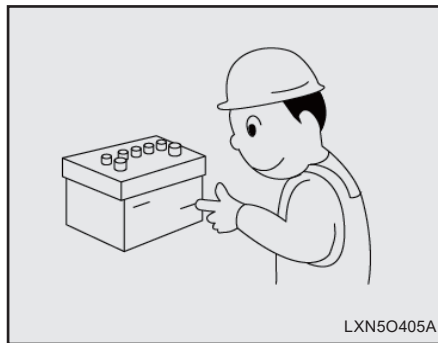

- Engine coolant level, leakage, or damage to the hose.

- Battery solution level.

- Air cleaner.

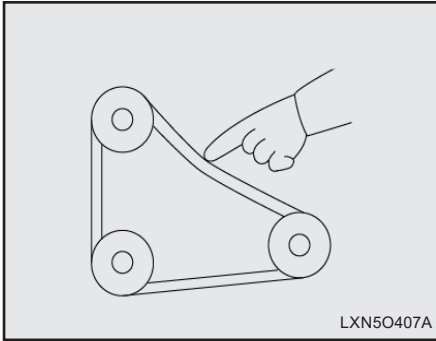

- Fan belt tension, damage.

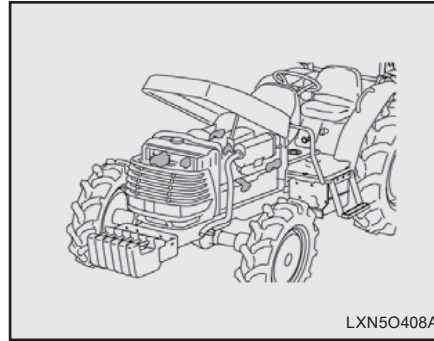

- Dust or straw on the radiator grill or the engine.



- Damage to the coating of the cables, or loosening of the contacts.

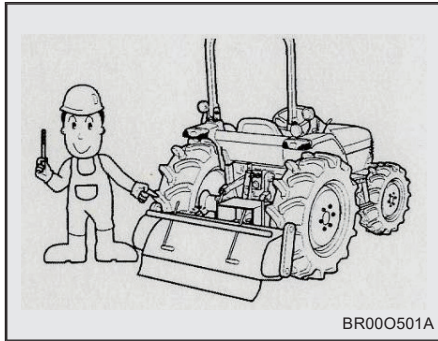

BR00O501A

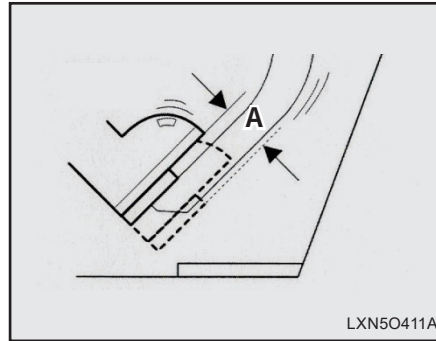

LXN5O411A

(A) Free Play

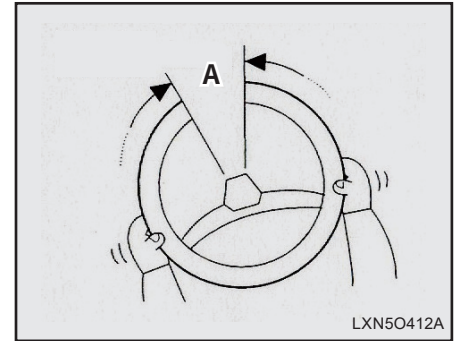

LXN5O412A

(A) Free Play

4. Check around the implement.

- Condition of the locking pin of the universal joint inserted in the PTO shaft.
- Condition of pins in each part.
- Loosening of the bolts holding the blade.
- Quantity of oil in each part. For more details, please refer to the implement manufacturer's instructions.

5. Check on the driver seat.

- Operational condition and free play of the brake. (0.2~0.4 in.)

- Free play of the steering wheel. (0.8~2.0 in.)

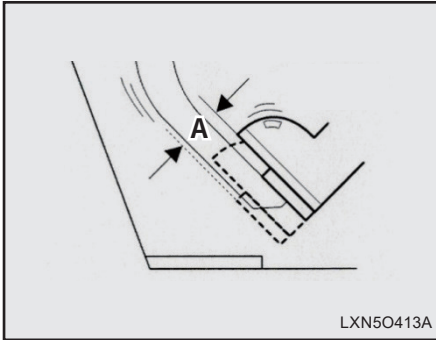

(A) Free Play: 1~1.4 in

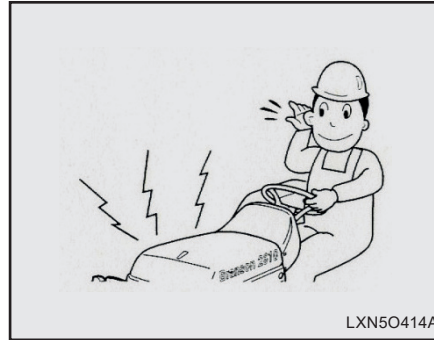

6. Start the engine.
- Abnormal noise from the engine.

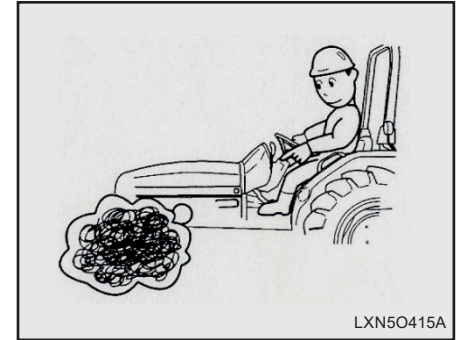

- Color of the exhaust gas.

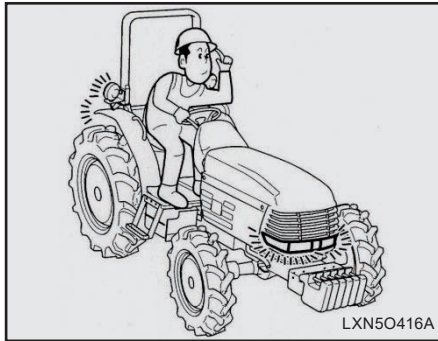

- Operation of lamps and gauges



► Boarding and Leaving The Tractor

Use Steps and Handholds Correctly

1. Prevent falls by facing the machine when getting on and off. Maintain 3-point contact with steps and handrails. Never use machine controls as handholds.

2. Use extra care when mud, snow, or moisture present slippery conditions. Keep steps clean and free of grease or oil. Never jump when exiting machine. Never mount or dismount a moving machine.

▲ DANGER

- Getting off the tractor, make the implement descend.

[Otherwise]

The implement descends itself, and then causes some unexpected accidents.

STARTING / STOPPING THE ENGINE

► **Note: Breaking in your tractor (First 50 hours)**

The operation of a new tractor during the first 50 hours is very important, as it will greatly influence the life and performance of the tractor.

Pay attention to the following precautions during the break-in period.

1. Avoid rapid accelerating and abrupt stopping.
2. Avoid over-speeding and overloads.
3. Drive the tractor after the engine has been warmed up.
4. Reduce the speed while driving on a rough road or a slope.
5. After the first 50 hours, carry out inspections of each part and replace the engine oil.

DANGER

- When starting the engine, make sure that you are seated in the driver's seat and check position of the levers and the safety around the tractor.

[Otherwise]

There is a risk of injury.

- Do not start the engine in an enclosed space. You must start the engine outside of building. If you have to start the engine inside a building, make sure that the space is well ventilated.

[Otherwise]

The exhaust gas can cause intoxication and can lead to fatal consequences.

CAUTION

- Make sure to carry out checking and maintenance before and after the use of the tractor, particularly the operating devices such as the clutch and the brake lever.

[Otherwise]

There is a risk of injury or machinery breakdown. Engage the parking brake during warming-up. Otherwise, the tractor may move and cause an accident.

- Don't crank engine unless hitch control lever is in the lowest position.

[Otherwise]

Implement might rise quickly and there is a risk of injury or machinery breakdown.

TO START THE ENGINE

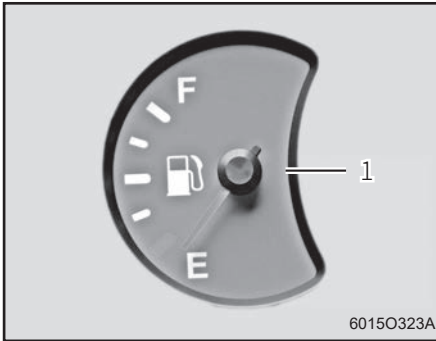

(1) Fuel Gauge

1. Check fuel.

- Check if there is enough fuel by observing fuel gauge.

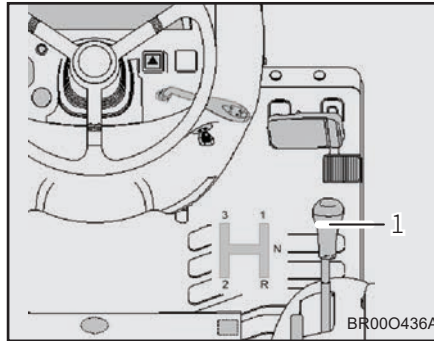

(1) Main Shift Lever

2. Put the main shift lever and PTO lever into "NEUTRAL" position.

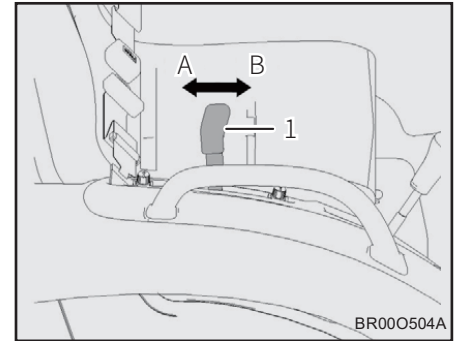

(1) Position Control Lever
(A) Raise (B) Lower

3. Put the position control lever into the "lowest" position.

WARNING

- Don't crank engine unless position control lever is in the lowest position.

[Otherwise]

Implement might rise quickly and there is a risk of injury or machinery breakdown.

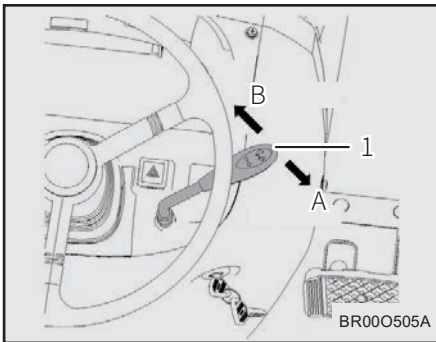
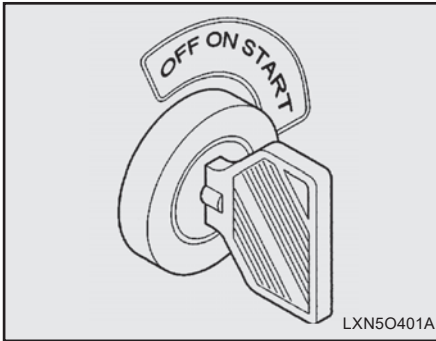

(1) Throttle Lever

(A) Increase (B) Decrease

4. Put the acceleration lever to Min a turn ignition switch to “ON” position.

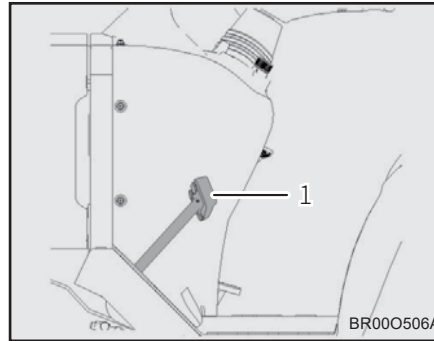

(1) Clutch Pedal

5. After the pre-heat lamp has turned off, depress the clutch pedal fully and turn the ignition switch to START.
6. Once the engine has started, take your hand off the ignition switch.

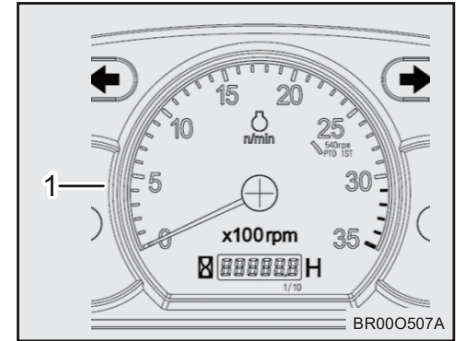

(1) Tachometer

7. Increase the engine to about 1,500 rpm and warm it up for about five minutes without a load.

CAUTION

- Never put your feet on the clutch pedal during driving or working.

[Otherwise]

It may cause an accident or quick wear of the clutch disks.

TO STOP THE ENGINE

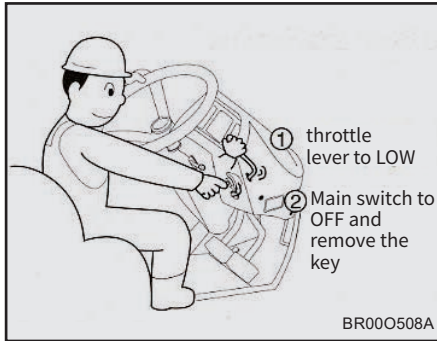

1. Put the throttle lever on LOW, and turn the main switch to “OFF”.
2. Put shuttle lever, main gearshift lever and PTO shift lever to “N”. put PTO ON/OFF switch in to the “OFF” position and front wheel lever to the “OFF”.
3. Put the position control lever on “DOWN”

⚠ CAUTION

- When stopping the engine, never stop it with the reducer lever.
- After stopping the engine, make sure to apply the parking brake.

NOTE

- For warming-up operation, strongly step on the brake pedal and pull your parking brake.

⚠ WARNING

- When leaving the tractor, park the tractor in a flat and safe place, put the shuttle lever and the main shift lever to “N”, and block the tires.

[Otherwise]

The tractor may move and cause an accident. Always set the parking brake.

TO RAISE OR LOWER THE IMPLEMENT

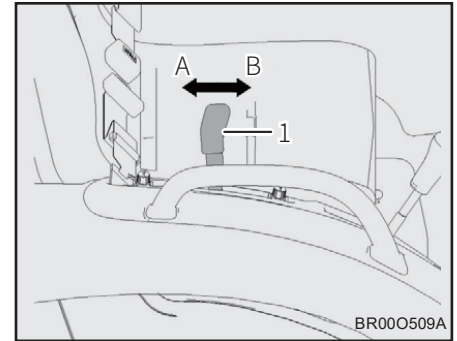

(1) Position Control Lever
(A) Lower (B) Raise

Move the position control lever forward or backward to lower or raise the implement.

ADJUSTING THE LOWERING SPEED OF THE IMPLEMENT

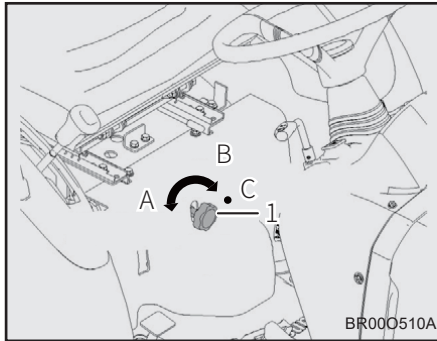

(1) Flow Control Valve
 (A) Fast (B) Slow
 (C) Stop

For adjusting the lowering speed, turn the hydraulic flow control valve (A) to the left for faster movement or to the right for slower movement. Turning the valve fully to the right will block the hydraulic pressure and will cause the implement to stop.

⚠ WARNING

- Do not work under or put a foot under the implement.

[Otherwise]

The implement may fall and cause an injury.

⚠ CAUTION

- When driving on a road, leave the hydraulic stop/slow return valve open and lock the position control lever into SHALLOW position.

DRIVING ON THE ROAD

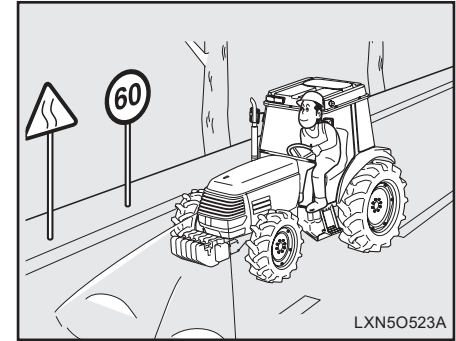

⚠ WARNING

- When driving on a road or crossing a dike, make sure to connect the brake pedals. Otherwise, the tractor may turn abruptly or turn over due to one-sided braking.
- Observe the traffic regulations when driving on the road. Otherwise, you may be involved in an accident.

DRIVING ON THE SLOPE

⚠ WARNING

- This tractor is designed to accommodate only one person. Do not allow anyone on the tractor other than the driver. Otherwise, you will be exposed to a risk of accident.
- Put the PTO lever into “N” and connect the brake pedals.
- When making a turn, turn on the direction indicator lamp to inform other vehicles of your intention.
- Monitor the vehicles coming from behind through the rear view mirror and do not hinder other vehicles from passing you.
- Pay particular cautions to narrow farm roads, slopes, and grassy shoulders, and reduce the speed.
- Put the position control lever to UP and lock it with the stopper. Otherwise, you will be exposed to a risk of an accident.

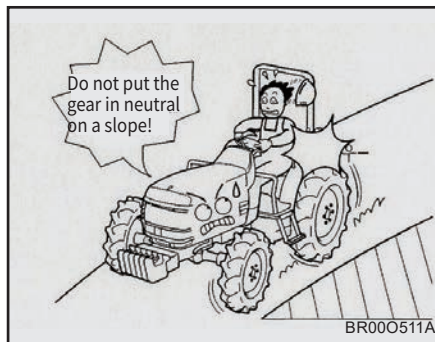

⚠ WARNING

- Select a proper speed, and do not shift the gear.
- Do not park on a slope. Otherwise, the tractor may slip or overturn and cause an accident.
- Reduce speed and pay special attention to the speed.

⚠ WARNING

- Do not depress the clutch pedal when driving on a slope. The tractor may slide down and lead to a serious situation.
- When starting the tractor upwards on a slope, start slowly in low gear with low engine rpm. Otherwise, the front of the tractor may be lifted and cause a very dangerous situation.
- You may shift the gear when you are no longer on the slope. If you stop on a slope, apply the parking brake. Otherwise, you may be exposed to a risk of accident.

ENTERING AND LEAVING THE PAVEMENT

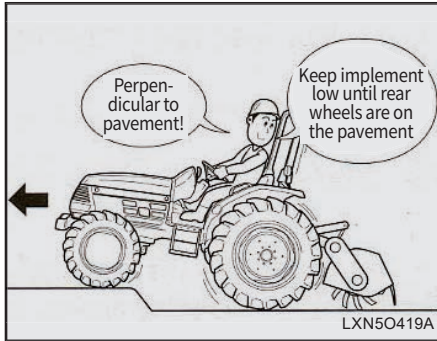

Enter or leave the pavement in a perpendicular direction. When climbing onto the pavement, lower the implement to achieve a lower center of gravity. Once all wheels of the tractor are on the pavement, raise the implement.

⚠ WARNING

- Make sure to connect the brake pedal. Otherwise, the tractor may turn over due to one-sided braking.
- When you cross a dike or raised ground to enter or leave the pavement, use loading ramps with sufficient strength, and lower the implement to achieve a lower center of gravity.
- Drive backward when climbing up a steep slope, and drive forward when climbing down.

NOTE

- Enter or leave the pavement in a perpendicular direction. When climbing onto the pavement, lower the implement to achieve a lower center of gravity. Once all wheels of the tractor are on the pavement, raise the implement.

TURNING ON THE PAVEMENT



When making a turn, reduce the engine rpm and make a slow turn. When making a turn on the pavement, remove the connector of the brake pedals. Depress the brake pedal on the side to which to make a turn, while steering the wheel, this will allow the tractor to make the turn without moving ahead. Make sure to keep the implement in the up position when making a turn.

DIFFERENTIAL LOCK

! WARNING

- Make sure to release the differential gear lock before making a turn.

[Otherwise]

The tractor will not turn in the intended direction. It may cause an accident.

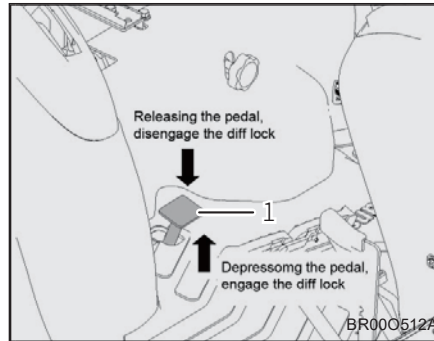

(1) Differential Lock Pedal

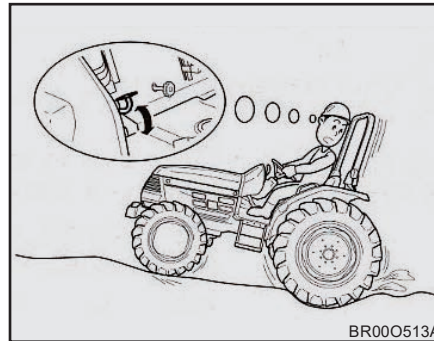

Depressing the differential lock pedal will make both rear wheels roll at the same speed. Releasing the pedal will automatically unlock the differential.

! WARNING

- Make sure to release the differential lock when making a turn.

[Otherwise]

The tractor will not turn in the intended direction and may cause an accident.

! CAUTION

- Never lock the differential when driving on a road.

[Otherwise]

Driving will be unstable and the tractor may cause an accident.

TRACTOR LOADING /UNLOADING

CAUTION

- When locking the differential gear, reduce the engine rpm.
- If the differential gear cannot be unlocked, disengage the clutch or depress the brake pedal lightly.
- Keep your feet away from the differential gear lock pedal except when you have it depressed.
- Don't use the differential gear lock with the Creep mode.

DANGER

- Fix the direction so that the tractor will not have to modify its direction on the loading bridge, and proceed at the lowest speed.
- Never depress the clutch pedal to change direction or stop.

[Otherwise]

There is a danger that the tractor may turn over.

WARNING

- Loading and unloading must be done on a flat and safe place, with the engine turned off and the parking brake engaged. The loading ramp must be non-slippery and have sufficient strength, length, and width for the tractor. To avoid slipping of the loading ramp, latch it securely onto the truck. Move the tractor backward when loading, and forward when unloading. Fasten the tractor to the truck securely with rope.

[Otherwise]

The tractor may fall off the truck and cause an accident.

PRECAUTIONS FOR CONNECTING THE IMPLEMENT

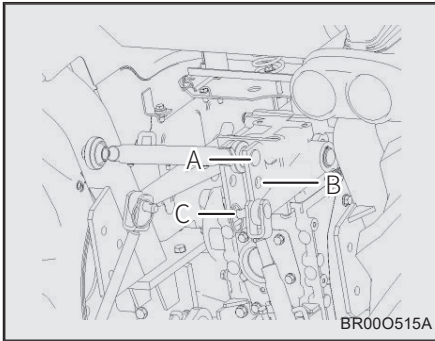

(A) Low Traction (B) Middle Traction
(C) High Traction

3. There are 2 holes in top link mounting bracket.
- ※ Top link needs to be moved from (A) to (B) as followed.
If rear side of implement is too high.

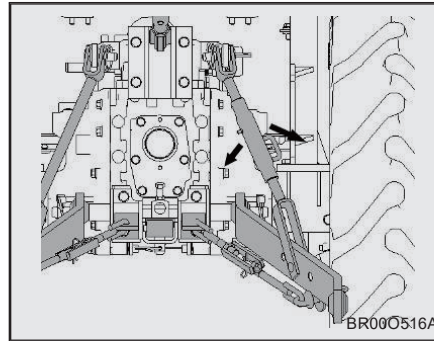

4. Level a 3 point mounted implement from side to side by turning the adjusting handle to shorten or lengthen the adjustable lifting rod with the implement on the ground.

⚠ CAUTION

- After adjusting, turn down the lever for locking.

1. When engaging or disengaging the implement by moving the tractor, make sure that no one is allowed around the tractor or between the implement and the tractor.
2. Engage or disengage the implement on a flat and safe place. Supply proper lighting at all times and especially at night.
3. When engaging a heavy implement, load the weight on the front to keep the balance of the tractor.
4. When adjusting the implement, apply the parking brake, switch off the engine, and confirm that the PTO lever is on the "N" position.
5. When towing something, make sure to use the drawbar.
6. Increase the wheel tread on a slope or when towing.

AUX. HYDRAULICS

7. Depending on the implement, the overall length may become very long. Pay particular attention to people or objects nearby when making a turn.
8. Do not substitute the balance weight with a person or anything else. Always use the recommended balance weight.
9. For front loader work, mount an implement on the rear to keep the balance of the tractor.
10. Read the instruction manual of the implement mounted to the tractor.

WARNING

- When the PTO shaft is not in use, affix the safety cover on it.

[Otherwise]

There is a risk of getting entangled in the tractor or injured.

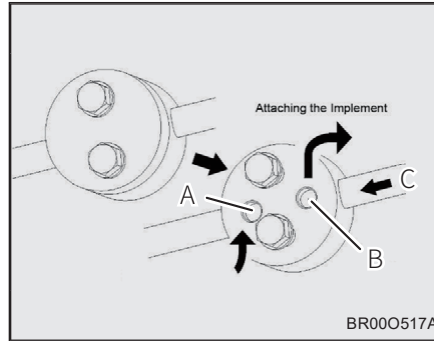

(A) Outlet (B) Inlet (C) Pump

Hydraulic block type outlet is useful when adding hydraulically operated equipment such as front loader, etc.

When implement is attached

1. Remove the block cover.
2. Attach the implement inlet and outlet.

NOTE

- For hydraulic block type outlet, be sure to use the control valve “Power beyond type” with relief valve that has a third line return to tank for the operation of hydraulic block.
- The “tank” port flow from implement should be connected to the port located on the right hand side of transmission case.
- If the implement control valve has a relief valve, the tank port flow from implement should be connected to the port located on the right hand side of transmission case.

ADJUSTING WHEEL TREAD

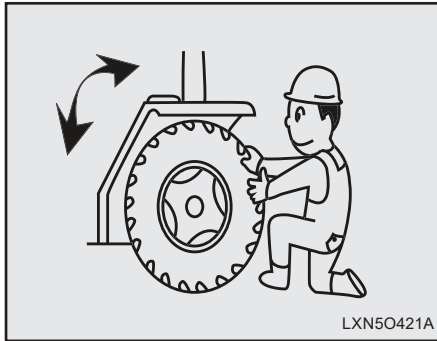

Adjust the wheel tread depending on the type and condition of the work. Also, increase the wheel tread when working on a slope or towing.

1. Pull the parking brake, block the front wheels, and raise the body with a jack to make the rear wheels separate from the ground.
2. To make sure adjustments alternatively between the left and right wheels.

[Tightening torque]

	DESCRIPTION	TIGHTENING TORQUE
Front wheel	Bolts on wheels and axle	56.8 ~ 66.4 lb-ft (77~90 N.m)
Rear wheel	Bolts on wheels and axle	79.6 ~ 92.2 lb-ft (108~125 N.m)

⚠ WARNING

- When changing tires, please use a hoist or strong support and make sure the tractor does not move.

[Otherwise]

There is a risk of death or injury.

POWER STEERING

⚠ CAUTION

- Pay attention to the steering wheels while driving, because it can be very lightly manipulated when the engine is running.
- Power steering will run only when engine is running. When engine is idling, power steering may feel a little heavy.
- If the wheels are steered to the maximum, the relief valve is opened and a warning sound will be made. Do not continue to operate the tractor with the warning sound.
- Do not steer the wheels unnecessarily, because steering the wheel without moving will contribute to early wear of tires and rims.

TOWING INSTRUCTIONS

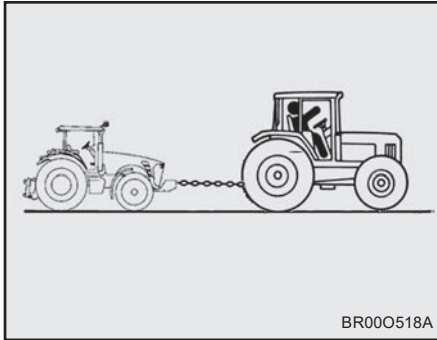

1. Tractor traction should be conducted in short distance. (For instance, from inside to outside)
2. Long distance towing is not allowed in traffic congestion.
3. In case tractor needs to tow, use strong and safechecked chain.
4. Traction must be conducted from the rear in usage of tow bar, tow hook and 3-point linkage.
5. When driver turns the handle, use the brake if necessary.
6. During traction, the transmission, not being lubricated but rotating or other parts in order to prevent breakage, please note the following:
7. Towing should be in short distance.
8. Traction speed is restricted to less 8km/h.
9. If possible, start the engine in order to make the power steering lubricated.
10. Place the main gearshift and sub gearshift in neutral.

PTO SPECIFICATIONS & PRE-CAUTIONS

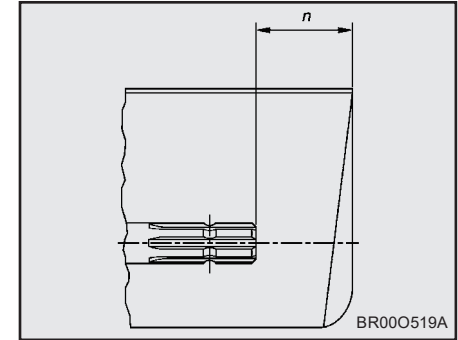

Wear close fitting clothing. Stop the engine and be sure that PTO driveline is stopped before making adjustments, connections, or cleaning out PTO driven equipment.

Do not install any adapter device that results in a portion of the rotating implement shaft, tractor shaft, or the adapter to be unguarded. The tractor master shield shall overlap the end of the splined shaft and the added adapter device as outlined in the table.

LOADER OPERATION

PTO Type	Diameter	Splines	n ± 0.2 in (n ± 5 mm)
1	1.378 in. (35 mm)	6	3.58 in (91 mm)

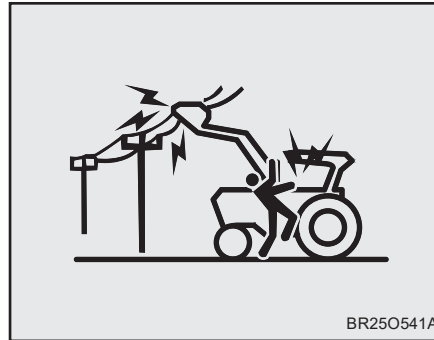
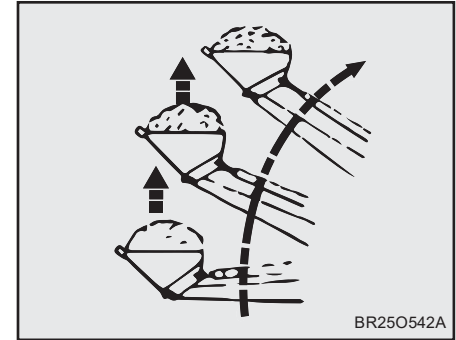
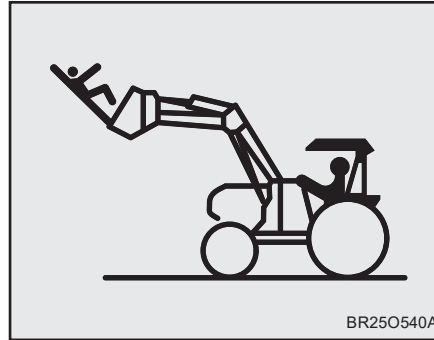

Work with front-end loader. (Risk of falling objects)

⚠ WARNING

To avoid serious injury or death:

- Do not lift or carry anyone on buckets, forks, spears or any other portions of the loader or loader attachments.
- Inadvertent movement of the loader or attachment could result in serious injury or death.

CARRYING THE LOAD

WARNING

- Avoid contact with electrical power lines by loader or attachments.
- Do not lift or carry anyone in the bucket or on any other position of loader attachment.
- Inadvertent movement of the loader or attachment could result in serious injury or death from falling or crushing.

CAUTION

- Make sure material in bucket cannot roll out and down on tractor when bucket is raised to full height.
- Keep clear of overhead obstructions such as trees, limbs or power lines when raising bucket.
- When lifting the load, keep the bucket positioned to avoid spillage.

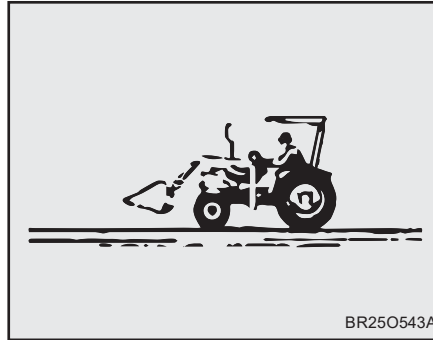

CAUTION

- Operating the loader on a hillside is dangerous. extreme care is recommended.

1. Position the bucket just below the level of the tractor hood for maximum stability and visibility, whether the bucket is loaded or empty.
2. Use extreme caution when operating the loader on a slope, keep the bucket as low as possible, this keeps the bucket and tractor center of gravity low and will provide maximum tractor stability.

HANDLING LARGE, HEAVY OBJECTS

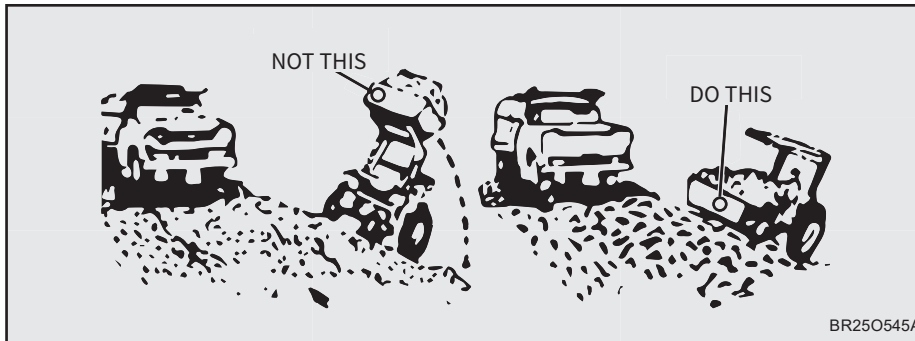
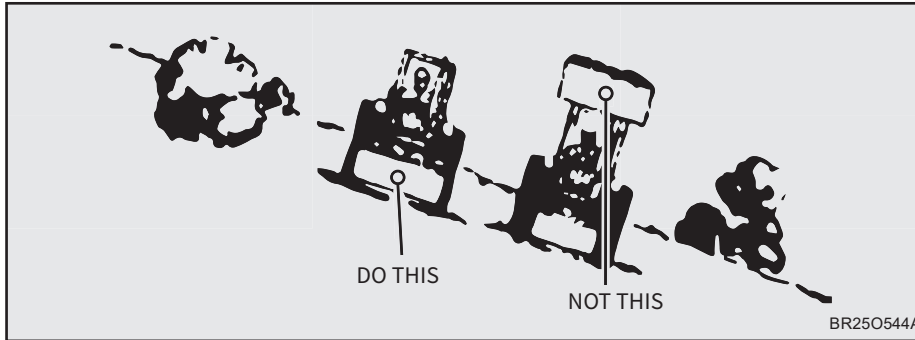

When transporting the load, keep the bucket as low as possible to avoid tipping, in case a wheel drops in a rut.

WARNING

- Do not use front end loaders for handling large, heavy objects such as large, round or rectangular bales, logs and oil drums.
- Handling large, heavy objects can be extremely dangerous due to.
 1. Possibility of rolling the tractor over.
 2. Possibility of upending the tractor.
 3. Possibility of the object rolling or sliding down the loader arms onto the operator.

CAUTION

- When transporting the load, keep the bucket as low as possible to resist tipping, in case a wheel drops in a rut. This will avoid tipping and possible injury.

⚠ CAUTION

- The following safety precautions should be thoroughly understood before attempting machine assembly.
- Do not lift heavy parts or assemblies. Use crane, jack, tackle, fork trucks, or other mechanical devices.
- Select an area for assembly that is clean and free of any debris which might cause persons working on the assembly to trip.
- Arrange parts to be assembled neatly in the work area and have tools and other mechanical assisting devices in easy reach.
- Inspect all parts and assemblies thoroughly and remove any sharp edges, grease, oil, or dirt which might cause pieces to slip when handling.

⚠ CAUTION

- Preview the assembly instructions in your operator's manual before proceeding further.
- If the assembly instructions call for parts or assemblies to be blocked up, use only blocking material that is in good condition and is capable of handling the weight of the assembly to be blocked. Also, insure that the blocking material is on a clean, dry surface.
- Never put hands or any other parts of body parts under blocked up assemblies if at all possible.
- Always wear goggles or safety glasses when hammering, grinding or drilling metal parts.
- If the assembly calls for welding or cutting, be sure that there are no flammable materials close at hand and that bystanders have taken necessary precautions.

ROPS FOLDING METHOD HOW TO FOLD DOWN THE ROPS

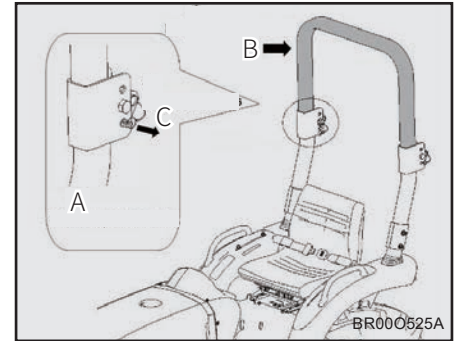

- (A) Pull the pins on both
(B) Push the safety frame
(C) Replace the pins

1. Turn the handle to separate the push plate and the **ROPS**.
 2. Pull the pins on both sides of the tractor and turn them about 1/4 turns to release the lock of the **ROPS**.
 3. Raise the **ROPS** a little.
 4. Replace the pin.
 5. Fold down the **ROPS**, and the pins will lock into place.
- ※ If it is not certain whether the pins are fixed, shake the frame a little bit to fix the pins for sure.

< How to fold up ROPS >

1. Pull the pins on both sides of the tractor and turn them about 1/4 turns to release the lock of the **ROPS**.
 2. Raise the **ROPS** a little.
 3. Replace the pins.
 4. Stand the **ROPS** up, and the pins will lock into place.
- ※ If it is not certain whether the pins are fixed, shake the **ROPS** a little bit to fix the pins for sure.
5. Turn the handle to fix the push plate and the frame.

⚠ CAUTION

- Don't fasten your seat belt after folding ROPS.
- When you drive tractor, fold up vertically.

[Otherwise]

If the tractor rolls over, you could be injured or death may occur.

⚠ CAUTION

- Fasten your seat belt after folding up ROPS.
- When working with the tractor, don't fold down ROPS.
- Don't change ROPS without authority.
- Before using tractor, check your ROPS support and other parts.
- If there is damage to the ROPS, change ROPS at once.

[Otherwise]

If the tractor rolls over, you could be injured or death may occur.

- ※ **ROPS** are a very important structure for protection on roll over, ALWAYS check your **ROPS**

MEMO

A series of horizontal dotted lines for writing.

6. MAINTENANCE AFTER WORK

MAINTENANCE AFTER WORK.....	6-2
MAINTENANCE FOR PROLONGED STORAGE.....	6-2

MAINTENANCE AFTER WORK

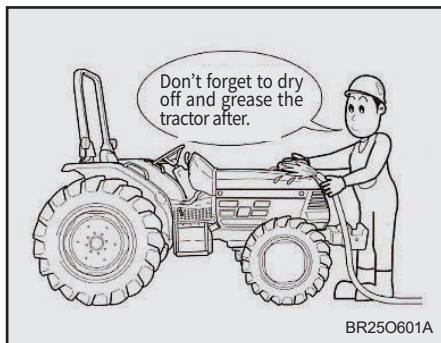

After work, clean the tractor. After cleaning, dry the moisture and supply grease into each grease nipple.

Avoid water on electrical parts whenever possible, as it will cause equipment breakdown.

⚠ DANGER

- When covering the tractor, make sure that the engine or the muffler has fully cooled down.

[Otherwise]

There is a risk of fire.

⚠ CAUTION

- When carrying out checking, maintenance, or repair, make sure to turn off the engine.

[Otherwise]

There is a risk that you may be entangled in the tractor or get injured.

MAINTENANCE FOR PROLONGED STORAGE

If you carry out maintenance during the off season, you can ensure optimum condition of the tractor as well as safe and comfortable working conditions during the busy season. Also, in order to secure the safety of each part of the tractor and to prevent an accident that may occur due to poor maintenance, arrange with your authorized dealer for periodic maintenance once a year.

In particular, we recommend that the electrical cables and the rubber hoses, such as fuel hose, steering wheel hoses and radiator hoses, be replaced every two years.

⚠ CAUTION

- When storing the tractor for a long time, take out the key and keep it in a safe place. Otherwise, there is a risk of accident.

[Otherwise]

There is a risk of getting entangled in the tractor or injured.

⚠ WARNING

- Carry out maintenance on a flat and safe place where the tractor will not fall or move and there is no traffic danger. Also, block the front tires to prevent moving of the tractor. Otherwise, there is a risk of accident, such as overturning of the tractor.
- Carry out checking and maintenance for each part every year.
- In particular, replace the fuel pipe and the steering wheel hose every two years. Otherwise, there is a risk of accident or machinery breakdown due to poor maintenance.
- When carrying out checking or maintenance, make sure to stop the engine.
- Replace the covers that have been detached for checking or maintenance.

⚠ WARNING

- Carry out checking or maintenance after heated parts, such as muffler, engine or transmission, have fully cooled down.
- [Otherwise]**
There is a risk of getting burnt.

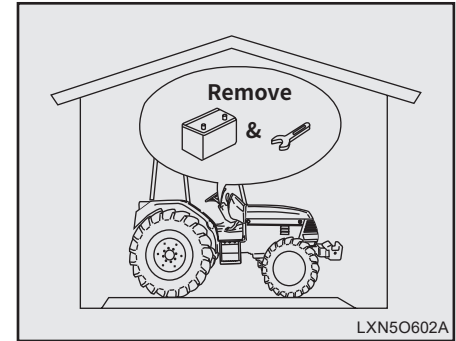

When the tractor will not be used for a long time, store it in the following manner.

1. For long storage, put the ignition switch to "OFF"
2. Select a dry and well-drained place for storage. Remove the weights & implement or put it down onto the ground.
3. Apply the anti-corrosion oil or engine oil and grease on the parts that are subject to rust.

4. Fill up the fuel tank. Empty space in the fuel tank will produce dew-drops that will produce condensation that will be the cause of rust formation. And lock the fuel cock to "C". (closed)
5. Disconnect the battery completely and store it away from the tractor in a well-ventilated, dry, dark place if possible. When the battery is attached to the tractor, make sure to connect the (+) terminal first.

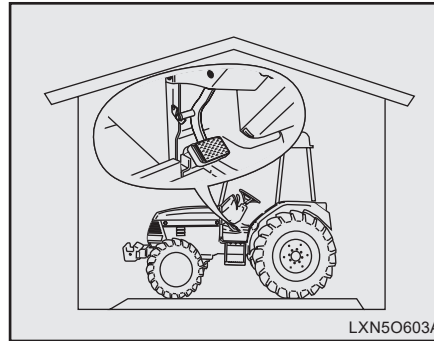

CAUTION

- The battery will be discharged even if it is not in use. Recharge it fully every 12 months.

6. Drain the coolant.
7. Cover the air cleaner, muffler, and engine oil inlet with plastic sheets to keep moisture away.
8. Keep the clutch pedal in a depressed position to avoid rust on the clutch.
9. Maintain the air pressure in the tires.

7. PERIODIC MAINTENANCE AND ADJUSTMENT

PERIODIC MAINTENANCE AND ADJUSTMENT	7-2	OTHERS	7-14
PERIODIC MAINTENANCE SCHEDULE	7-3	RADIATOR SCREEN & AIR CLEANER ELEMENT	7-14
OIL, GREASE AND ANTI-FREEZE CHART	7-5	BATTERY	7-15
FUEL, OIL AND COOLANT CHART	7-6	PIPES AND HOSES	7-15
OPENING AND CLOSING OF HOOD AND SIDE COVERS.....	7-7	ELECTRICAL CABLES.....	7-16
CHECKING AND CHANGING OILS.....	7-7	GREASING	7-17
ENGINE OIL	7-7	CLUTCH	7-17
TRANSMISSION OIL	7-8	STEERING WHEEL	7-18
FRONT AXLE FLUID	7-9	BRAKE	7-18
FILTERS / COOLANT REPLACEMENT	7-10	FAN BELT	7-19
ENGINE OIL FILTER	7-10	TOE-IN	7-20
TRANSMISSION OIL FILTER	7-11	FUSE & FUSIBLE LINKS.....	7-21
FUEL FILTER	7-11	COLOR OF EXHAUST GAS.....	7-21
DRAINING AIR IN FUEL LINE	7-12	TIRES	7-22
COOLANT	7-12		

PERIODIC MAINTENANCE AND ADJUSTMENT

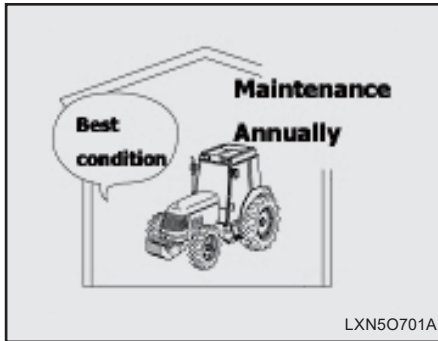

⚠ WARNING

Carry out maintenance on a flat and safe place where the tractor will not fall or move and there is no traffic danger. Also, block the front tires to prevent moving of the tractor.

[Otherwise]

There is a risk of accident, such as overturning of the tractor.

⚠ CAUTION

- Carry out checking and maintenance for each part every year.
- In particular, replace the fuel pipe and the steering wheel hose every two years. Otherwise, there is a risk of accident or machinery breakdown due to poor maintenance.
- When carrying out checking or maintenance, make sure to stop the engine.
- Replace the covers that have been detached for checking or maintenance.

[Otherwise]

There is a risk of getting entangled in the tractor or injured.

⚠ CAUTION

- Carry out checking or maintenance after heated parts, such as muffler, engine or transmission, have fully cooled down.

[Otherwise]

There is a risk of getting burnt.

If you carry out maintenance during the off season, you can ensure optimum condition of the tractor as well as safe and comfortable working conditions during the busy season. Also, in order to secure the safety of each part of the tractor and to prevent an accident that may occur due to poor maintenance, arrange with your authorized dealer for periodic maintenance once a year.

In particular, we recommend that the electrical cables and the rubber hoses, such as fuel hose, steering wheel hoses and radiator hoses, be replaced every two years.

MAINTENANCE SCHEDULE CHART

○ : Check · Add · Adjust ● : Replace
 ★ : Replace at first time only △ : Clean

INSPECTION PART	HOUR														YEAR	
	50	100	150	200	250	300	350	400	450	500	550	600	650	700	1YR	2YR
ENGINE OIL LEVEL	CHECK BEFORE EVERY WORK															
ENGINE OIL & FILTER	★					●					●				●	
FUEL FILTER										●						
FUEL HOSE & BAND	CHECK BEFORE EVERY WORK															●
AIR CLEANER ELEMENT		△		△		△		△		●		△		△		●
AIR CLEANER HOSE & BAND	CHECK BEFORE EVERY WORK															●
INLET HOSE & BAND	CHECK BEFORE EVERY WORK															●
COOLANT																●
COOLANT LEVEL	CHECK AND ADD BEFORE EVERY WORK															
RADIATOR & RADIATOR NET	CHECK AND CLEANING BEFORE EVERY WORK															
RADIATOR HOSE & BAND	CHECK BEFORE EVERY WORK															●
FAN BELT & A/C BELT		○		○		○		○		○		○		○		
BATTERY		○		○		○		○		○		○		○		

- ※ Replace the fan belt & a/c belt as required.
- ※ Charge and replace the battery as required.
- ※ Inspection should be done every 50 hours. If the tractor is not used much, inspect every year.
- ※ Replace a part at running hour or year whichever comes first.

○ : Check · Add · Adjust ● : Replace
 ★ : Replace at first time only △ : Clean

INSPECTION PART	HOUR														YEAR	
	50	100	150	200	250	300	350	400	450	500	550	600	650	700	1YR	2YR
TRANSMISSION OIL	★	○	○	○	○	○	●	○	○	○	○	○	○	○		
TRANSMISSION OIL FILTER	★	○	○	○	○	○	●	○	○	○	○	○	○	○		
FRONT AXLE OIL	★	○	○	○	○	○	●	○	○	○	○	○	○	○		
FUEL PIPE & CONNECTION	CHECK BEFORE EVERY WORK															●
STEERING WHEEL HOSE	CHECK BEFORE EVERY WORK															●
HYDRAULIC OIL HOSE		○		○		○		○		○		○		○		
ELECTRIC CABLES	CHECK BEFORE EVERY WORK															
GREASING	CHECK BEFORE EVERY WORK															
TIGHTENING HANDLES		○		○		○		○		○		○		○		
TIGHTENING BOLTS & NUTS	○	○		○		○		○		○		○		○		
CLUTCH		○		○		○		○		○		○		○		
BRAKE		○		○		○		○		○		○		○		
ENGINE BREED PIPE	○	○		○		○		○		○		○		○		
ENGINE CRANKCASE						△						△				
INTAKE/EXHAUST GAS VALVES												○				
FUEL INJECTION VALVE												○				
GENERATOR MOTER	○	○				○				○				○		
HYDARAULIC SYSYEM	○	○				○				○				○		

OIL, GREASE AND ANTI-FREEZE CHART

NO	ITEM	TYPE	REMARK
1	Fuel	Diesel (Summer : S, Winter : W)	Use winter diesel when temperature in below 50°F
2	Engine oil	SAE 10W-40	CG Above
3	Grease	Arctic Grease Below 14°F (-10°C) SAE (NLGI) #0, #1 32~-22°F (0~-30°C) SAE (NLGI) #2 32~122°F (0~50°C)	
4	Coolant Anti - Freeze	ASTM D4985 Extended Life antifreeze	
5	Transmission / Steering/Front axle oil	TYM Origin Oil Texaco TDH oil, 1893	
6	Front axle oil	SAE 80W-90	

FUEL, OIL AND COOLANT CHART

gal (ℓ)

NO	ITEM	CAPACITY					
		2,400	2,400H	2510	2510H	2610	2610H
1	Fuel	6.08 (23.00)					
2	Engine oil	0.79 (3.00)					
3	Coolant	1.21 (4.60)					
4	Transmission / Hyd oil	2.90 (11.00)	2.64 (10.00)	2.90 (11.00)			
5	Front axle	0.79 (3.00)					

IMPORTANT

- Above listed fuel, oil and coolant table is only for initial filling, and may be reduced at the time of replace.

OPENING AND CLOSING OF HOOD AND SIDE COVERS

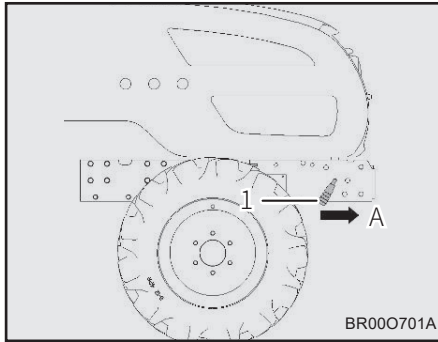

(1) Hood Open Lever
(A) Pull

1. Press the hood open lever to release the lock of hood.
2. Raise the hood with both hands.
3. When closing the hood, press the front part of hood until a clicking sound is heard.
4. After closing the hood, try to pull up the hood to see if the hood is securely locked in place.

CHECKING AND CHANGING OILS

Do not dispose of waste oils in the sewage system, and take appropriate measures such as contacting a waste oil disposal specialists.

⚠ DANGER
<ul style="list-style-type: none"> • Never fill the fuel tank when the engine is running or hot. <p>[Otherwise] There is a danger of fire.</p>

⚠ CAUTION
<ul style="list-style-type: none"> • Do not change the oil right after stopping the engine. <p>[Otherwise] There is a danger of getting burnt.</p>

ENGINE OIL

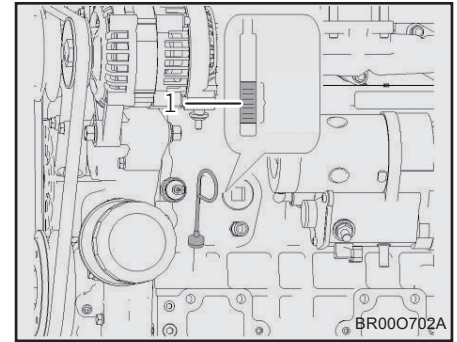

(1) Engine Oil Filler

► CHECKING OIL

Pull out the dipstick, clean the tip of dipstick, put it back into the engine, and pull it out again to see if the oil level is between the upper and lower limit. If the oil level is below the lower limit, add oil.

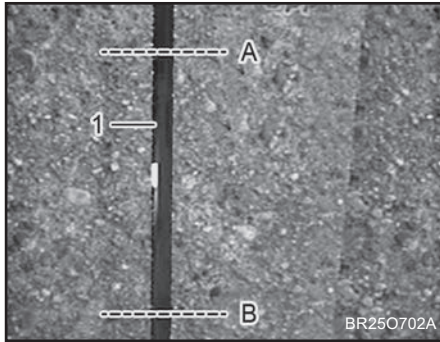

(1) Dipstick
 (A) Upper Limit (B) Lower Limit

⚠ CAUTION

- Check the oil level before the engine is started or after the engine is cooled down.

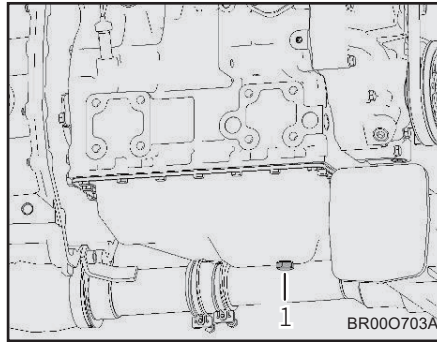

(1) Drain Plug

► **CHANGING OIL**

Drain the oil by removing the plug under the engine. Put new oil through the engine oil filler hole. Change the oil periodically, and select the right type of oil depending on the temperature and usage.

⚠ CAUTION

- Drain the oil when oil is warm but be careful. If oil is hot, there is a risk of getting burnt.

TRANSMISSION OIL

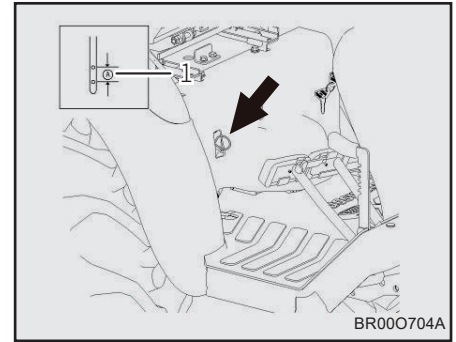

(1) Inspection Gauge

► **CHECKING**

Check the fluid level through the inspection window at the rear side of the transmission compartment. The level should be within sight through the inspection gauge. If the fluid level is below proper level, add fluid

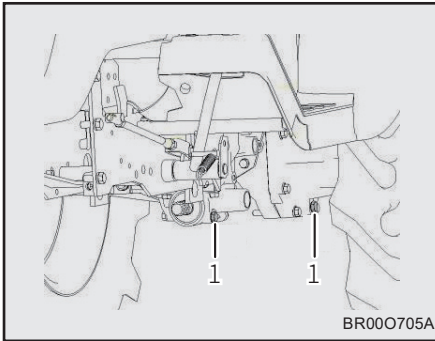

(1) Drain Plug

⚠ CAUTION

- Drain the oil when oil is warm but be careful. If oil is hot, there is a risk of getting burnt.

FRONT AXLE FLUID

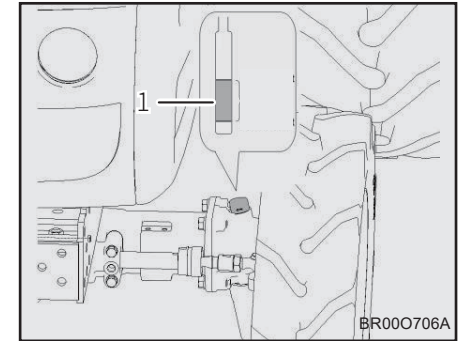

(1) Front Axle Oil Filler

► CHANGE OF FLUID

Drain the fluid through the drain holes under the rear axle case and rear axle housing. Supply the fluid through the filler hole behind the hydraulic case.

1. Transmission oil can be used for the hydraulic system and for the power steering unit.
2. Make sure to the genuine **TYM** transmission fluid.

► CHECKING OIL

Open the fluid filler cap on the upper right side of the front axle, clean the tip of the gauge, dip the cap without screwing in, and take it out again to read the fluid level. Refill the fluid as necessary, and also check for leaks.

FILTERS / COOLANT REPLACEMENT

ENGINE OIL FILTER

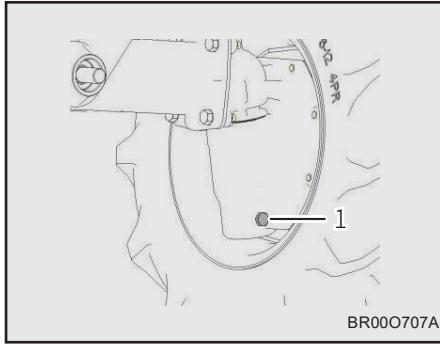

(1) Drain Plug

► CHANGING OIL

Drain the fluid through three drain holes under the front axle.

Refill the fluid from the upper right side of the front axle

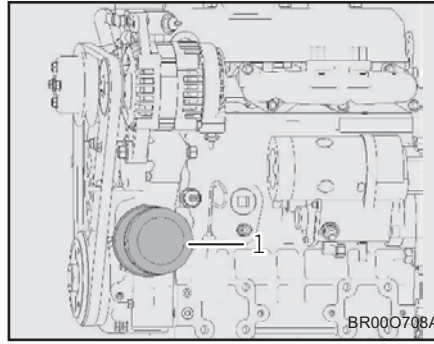

(1) Engine Oil Filter

Replace it every 300 hours or when engine oil is changed.

NOTE

- First 50 hours, filter has to be changed.

► REPLACEMENT

1. After draining the engine oil, turn the cartridge to the left with the filter wrench.
2. Apply a thin film of oil over the rubber ring on the bottom of the new cartridge and attach the new filter securely.
3. After changing the engine oil, start the engine and run it until the engine oil pressure warning lamp is turned off.
4. After the oil pressure warning lamp is turned off, check the oil level again. Add oil as necessary.

TRANSMISSION OIL FILTER

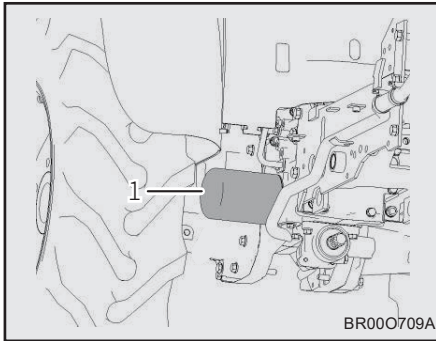

(1) Transmission Oil Filter

The filter is a cartridge type.

NOTE

- First 50 hours, filter has to be changed.

► REPLACEMENT

1. After draining the transmission fluid, turn the cartridge to the left to take it out.
2. Apply a thin film of fluid over the rubber ring on the bottom of the new cartridge and attach the new filter securely.
3. After changing the transmission fluid, start the engine to circulate the fluid and then stop the engine. Check the fluid level at dipstick on left axle housing and add fluid as necessary.

FUEL FILTER

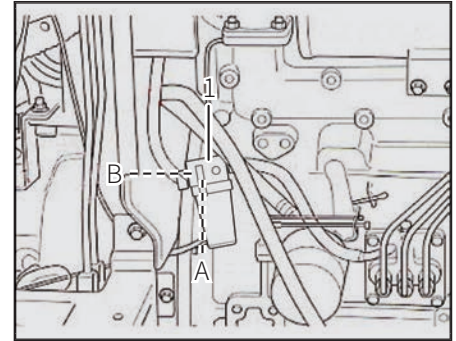

(1) Fuel Filter

(A) Open

(B) Close

Cleaning and replacement of fuel filter element

1. Put the fuel cock to “B” position
2. Take out the filter and remove water and dust inside the filter.
3. After cleaning the filter, replace it and put the fuel cock to “A” position. Remove the air.
4. Replace the filter element.

DRAINING AIR IN FUEL LINE

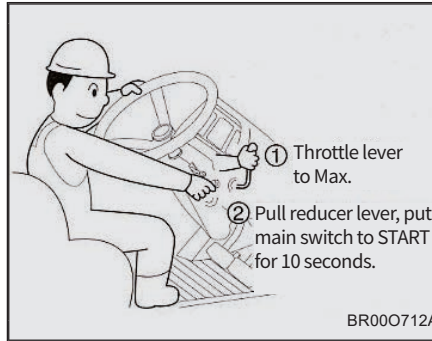
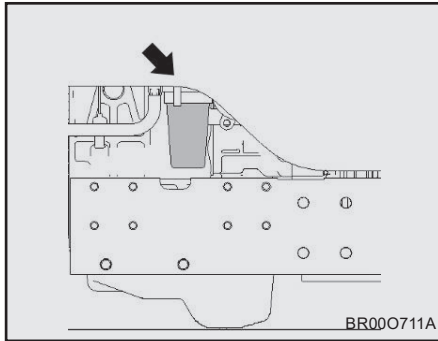

Drain the air from the fuel tank, fuel filter, and fuel filter element when the engine stops as the fuel runs out or during maintenance

1. Refill fuel to fuel tank.
2. Put the fuel filter valve to "OPEN."
3. Put the throttle lever to MAX and the key switch to START to run the starting motor for about 10 seconds. That completes the procedure.

NOTE

- If air is not removed, then there will be air in the fuel lines. Please check fuel lines for leakage or breakage.

COOLANT

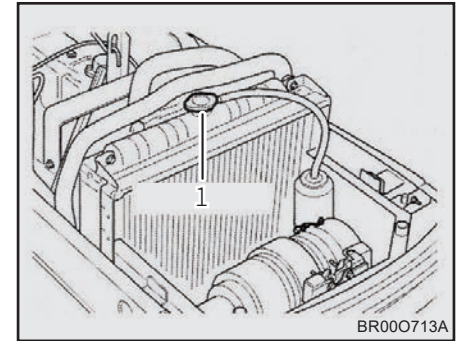

(1) Radiator Cap

► CHECKING

Open the engine hood and the side cover and see if the water level in the reservoir is between the upper and lower limit. Add clean water as necessary.

► REPLACEMENT

1. Open the radiator cap and the drain plug to completely drain the water from the radiator.

2. Rinse the radiator with tap water until no dirt or rust comes out.
 - ✧ For better results, fill the radiator with water mixed with radiator flush, run the engine for over 15 minutes, and drain the water solution
3. Assemble the drain plug, add anti-freeze and fill the radiator with tap water.
4. Assemble the radiator cap and run the engine to mix the anti-freeze and water.

⚠ DANGER

- Do not open the radiator cap while the engine is running or right after the engine is stopped. Open the radiator cap only after the engine is stopped and fully cooled down.

[Otherwise]

Hot water will splash and may cause burn injury

▶ HANDLING OF ANTI-FREEZE

Anti-freeze has an effect of lowering the freezing point of water. This tractor is filled with international genuine anti-freeze when delivered from the factory. As the freezing point may differ depending on the mixture ratio, refer to the following table in very cold weather to ensure safety.

▶ ANTI-FREEZE MIXTURE RATIO

Outdoor Temp (°F)	23	14	5	-4	-13	-22
Water (%)	82	73	66	61	55	49
Anti-Freeze (%)	18	27	34	39	45	51

⚠ CAUTION

- When replacing the coolant, add anti-corrosive solution and run the engine for about five minutes to mix it with the water.
- For correct mixture ratio, refer to the manufacturer's instructions.
- When refilling the coolant, add only tap water.
- As anti-freeze expires in one year, replace the coolant every year.

OTHERS

RADIATOR SCREEN & AIR CLEANER ELEMENT

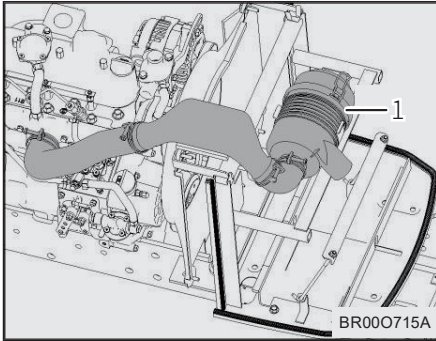

(1) Air Cleaner

The Air cleaner removes the dust mixed in the intake air, thereby preventing abrasion of cylinder liners and piston rings to keep the engine in good condition. When working in dusty environments, clean the air filter every 50 hours and replace it every 400 hours.

In normal working environments, clean the air filter every 100 hours and replace it every 1,000 hours. If the running hours are shorter, replace the element after one year.

► CLEANING OF AIR CLEANER

Open the cover and take out the element. Blow air inside the element or shake it to take the dust off the element. Be careful to avoid damage to the pins.

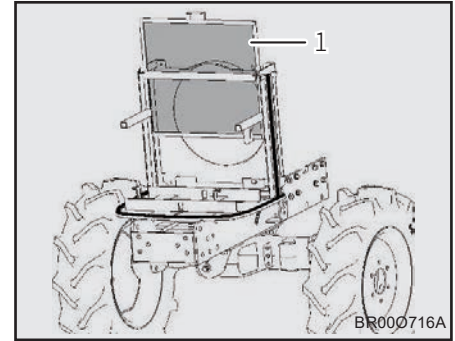

(1) Radiator Screen

► CLEANING OF RADIATOR SCREEN

Unscrew the butterfly bolt, pull up the radiator screen to take it out. Remove straw and dust. Clean it before and after working.

BATTERY

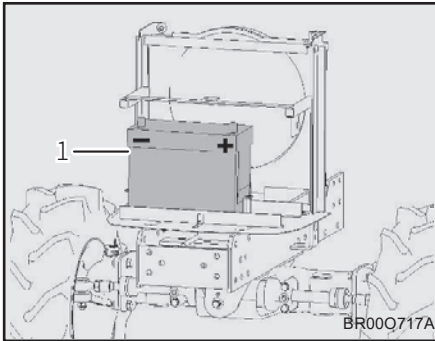

(1) Battery

1. When replacing the battery, make sure to install the battery of the same capacity as designated in the instruction manual.
2. To preserve the environment and to recycle resources, do not discard the old battery and hand it over to the battery dealer for proper disposal.

⚠ DANGER

- Avoid heat when checking or charging the battery.

[Otherwise]

The battery may explode and cause burns or other injury.

⚠ CAUTION

- When connecting the battery cable, connect the (+) terminal first. When disconnecting the cable, disconnect the (-) terminal first.

[Otherwise]

There is a risk of getting burnt due to shorting of the battery.

PIPES AND HOSES

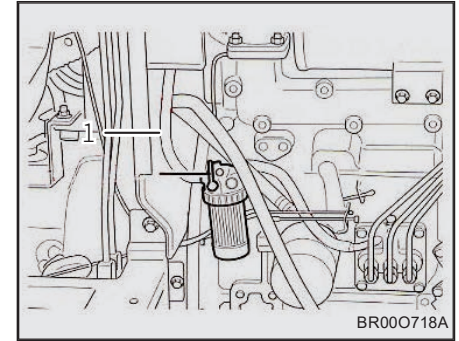

(1) Fuel Pipe

Check for damage to fuel hoses, power steering hoses (pipe), and radiator hoses, and see if there is any leakage or loosening of bolts.

Replace the pipes and hoses every two years even though they are not damaged.

ELECTRICAL CABLES

⚠ CAUTION

- When replacing the fuel hose, drain air.

⚠ DANGER

- Inspect the condition of the fuel hoses and check for fuel leakage from any damaged parts of the hoses.

[Otherwise]

There is a risk of fire.

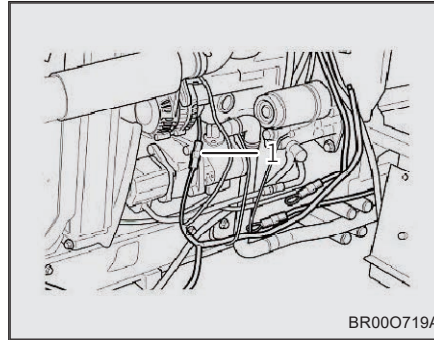

(1) Electric Cable

Open the hood of the engine and check if any cable is in contact with other parts, or if any insulation is peeled off or damaged, or any contact is loosened.

Damaged cables must be repaired by an authorized dealer. Arrange for periodic maintenance for cables every 50 hours or once a year even though the cables are not damaged.

⚠ DANGER

- Before starting to work everyday, check if any cable is in contact with other parts, or if any insulation is peeled off or damaged, or any contact is loosened.
- Before and after work, remove any straw or dust on the battery or cables.
- Inspect cables and wire connectors for any loose of damage

[Otherwise]

There is a risk of fire due to short circuit.

GREASING

Apply grease every 50 hours. Check the relevant parts before starting work every day and add grease as necessary. After working on a watered farm, make sure to apply grease to the tractor.

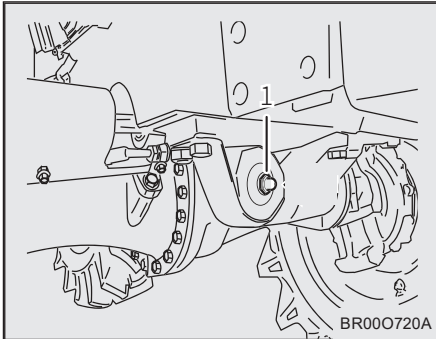

(1) Front Axle Support



(1) Tie Rod LH / RH

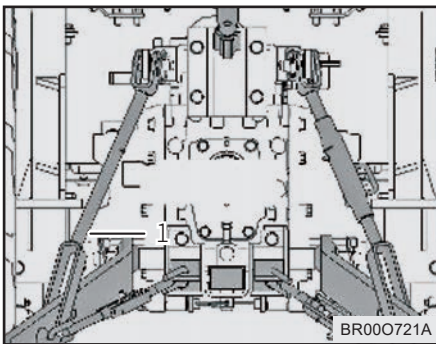

(1) Lift Link (R)

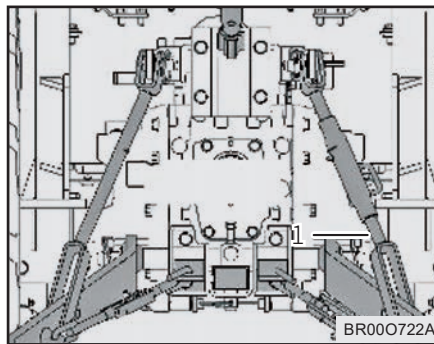

(1) Lift Link (L)

CLUTCH

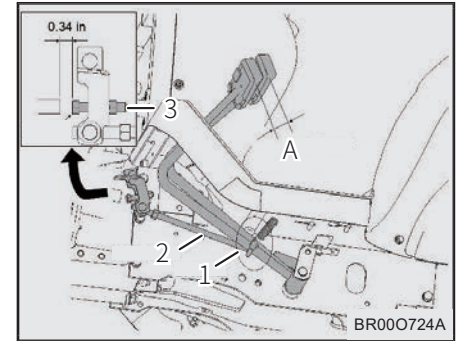

- (1) Lock Nut
- (2) Clutch Rod
- (3) Adjust Bolt
- (A) Free Play : 0.1~1.4 in (2.5~35.6 mm)

Adjust clutch pedal as follow.

1. Stop the engine and remove the key
2. Slightly depress the clutch pedal and measure free play at top of pedal stroke.
3. If adjustment is needed, loosen the lock nut and turn the clutch rod to adjust the rod length within acceptable limits.

STEERING WHEEL

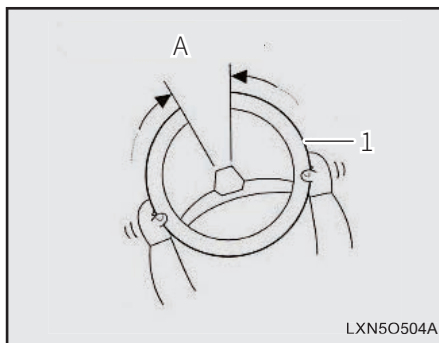

(1) Steering Handle

(A) Free Play : 0.8~ 2.0 in (20.3 ~50.8 mm)

When the steering wheel is turned lightly, there should be free play 0.8~2.0 in. If the extent of the free play exceeds this range, the steering wheel may feel heavy or the tractor may not move straight. If the free play is not normal, have it fixed at your nearest authorized dealer.

WARNING

- Make sure that the steering wheel does not vibrate severely or has enough free play.

[Otherwise]
there is a risk or accident.

BRAKE

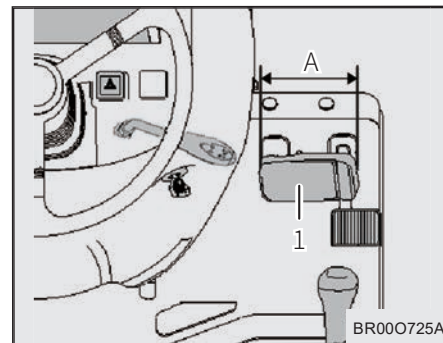

(1) Brake Pedal

(A) Free Play : 1.2 in~ 1.5 in (30~40 mm)

WARNING

- Check the brakes to avoid one-sided braking. Otherwise, there is a risk of accident.
- If the extent of free play is different between the two brakes pedals, one-sided braking will occur. Make sure that the free play of both brake pedals is the same.

- In this case, the free play of the brake pedal is 1.2~1.5 in (30~40 mm).
- Adjust both of the brake pedals.

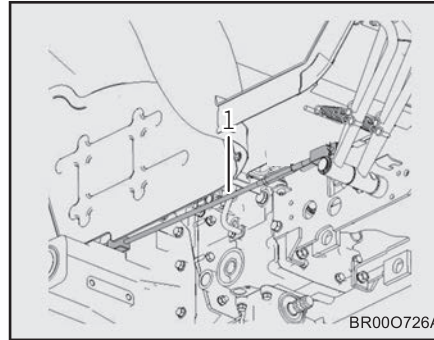

(1) Brake Rod (R)

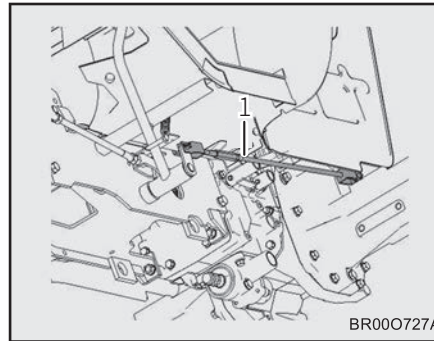

(1) Brake Rod (L)

FAN BELT

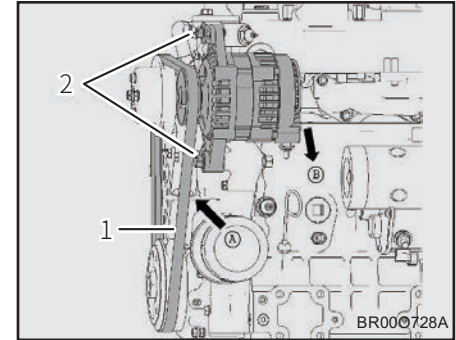

(1) Fan Belt

(2) Bolt

Open the engine hood and press the middle of fan belt with finger to see if the belt sags about 0.4~0.6 in or if there is any damage to the belt. If the sagging is not correct, loosen the generator bolt and move the generator to adjust the tension of the fan belt. If the fan belt still slips after the generator is moved to the maximum, replace the belt with a new one. New belts must be inspected after 50 hours of use.

⚠ CAUTION

- Carry out inspection or maintenance after the engine is fully cooled down.

[Otherwise]

There is a risk of getting burnt.

TOE-IN

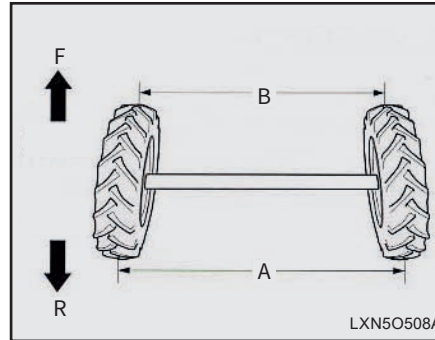

(F) Front

(R) Rear

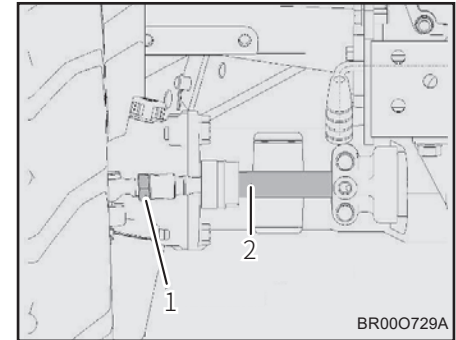

(1) Tie Rod Nut

(2) Cylinder Rod

► CHECKING

If the toe-in is not properly aligned, the steering wheel may be uncontrollable or the tractor may produce an abnormal vibration. Measure the distance A and the distance B of the front wheels and see if the different between the two measurements is 0.16 ~ 0.3 in (4~8 mm).

► ADJUSTING

If not, loosen nuts at the end of the cylinder rod on both sides and adjust the length of the screws. Tighten the nuts when the toe-in is 0.16 ~ 0.3 in (4~8 mm).

Left and right adjustment of screw length must be same.

FUSE & FUSIBLE LINKS

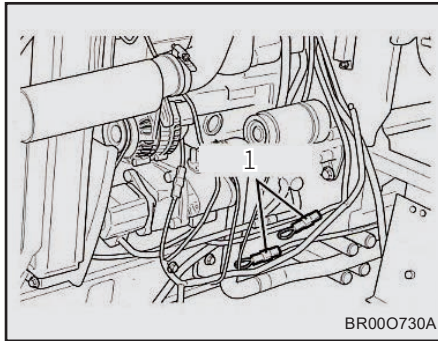

(1) Fusible Links

Stop the engine and check the main fuse. (Fusible link)

Open the fuse box cover and check the fuses. Replace any burnt-out fuses with new ones of required capacity.

A fusible link is a type of fuse, which burns and disconnects the current in the event of excessive current flowing in the circuit, if plastic coating is discolored when it is cut off, it should be inspected by a authorized dealer.

If the fuse burns immediately after being replaced, it must be checked by the authorized dealer.

WARNING

- When replacing the fuse, use only the one of the same capacity.

COLOR OF EXHAUST GAS

The exhaust gas may be a little black at the time of starting the engine, but normally its color is clear.

- Black – Incomplete combustion due to too much fuel intake.
- White – Misfiring or cold temperature.
- Blue – Burning of engine oil

If the color of the exhaust gas remains black or white during operation, have the tractor inspected at your nearest authorized dealer.

TIRES

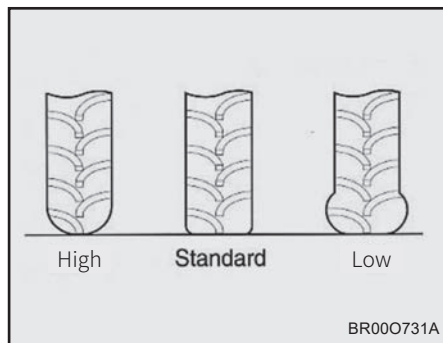

AIR PRESSURE IN TIRES

		Air pressure(psi)
		2400(H),2510(H),2610H
Rear	9.5 - 16 6PR	30
	33×12.5 - 16.5 4PR	30
	12 - 16.5 6PR	40
Front	6 - 12,4PR	28
	23×8.50 - 12, 4PR	22
	23×8.50 - 12, 6PR	35

Adjust air pressure in front and rear tires to standard pressure.

Also, check if there are any cracks on the tires.

When front wheels are put under a load of the front weights or a front loader, air pressure in the front wheels must be adjusted to the maximum in the chart as followed.

TORQUE OF WHEEL BOLTS

Type	Torque (lb-ft)
Front wheel	75 ~ 87
Rear wheel	192 ~ 224

8. TROUBLE SHOOTING

TROUBLESHOOTING	8-2
ENGINE.....	8-2
CLUTCH AND BRAKE.....	8-4
HYDRAULIC SYSTEM	8-5
ELECTRICAL SYSTEM	8-6

TROUBLESHOOTING ENGINE

If the tractor is not working properly, stop the engine and carry out an inspection based on the following table.

SITUATION	INSPECTION ITEM	SOLUTION
1. The motor does not start when the main switch is turned to START.	Are you depressing the clutch?	Depress the clutch fully and turn the main switch to START
	Is the battery solution enough?	Fill the battery solution and fully charge the battery.
	Is the battery discharged?	
	Is the battery terminal loosened or corroded?	Clean and tighten the terminals. Apply grease to avoid rust
	Is the main fuse burnt out?	Replace the fuse
	Is the key switch broken?	Contact the dealer for repair or replacement.
	Is the starting motor out of order?	Contact the dealer for repair or replacement.
2. The motor starts, but the engine does not start.	Is the fuel tank empty?	Fill up the fuel tank and drain the air.
	Is the fuel mixed with air?	Drain the air from the fuel.
	Does the engine run only when the reducer lever is pulled?	Charge the battery.
	Is the fuel cock on "C"?	Put the fuel cock on "O"
3. The engine revolution is irregular.	Is the air mixed in the fuel system?	Drain the water and replace the fuel.
	Is the injection nozzle clogged?	Have the injection nozzle repaired or replaced
	Is the fuel filter clogged?	Have the fuel filter washed or replaced.

SITUATION	INSPECTION ITEM	SOLUTION
4. The engine is over heated	Is the coolant level low?	Refill the coolant.
	Is the fan belt slack or damaged?	Adjust or replace the fan belt.
	Is the radiator fan clogged?	Clean the radiator fan.
	Is the engine oil lever low?	Refill the engine oil.
	Is the engine running under too much load?	Reduce the load.
5. The engine power is too weak.	Is the air cleaner clogged?	Inspect the air cleaner
	Is the nozzle stained with carbon?	Contact the dealer for repair
	Is the compression force weak?	
	Is the valve clearance adjusted properly?	
	Is the injection timing bad?	
6. Coolant warning lamp is in during operation.	Is the coolant level in the reservoir low?	Refill the coolant
7. Engine oil warning lamp is on during operation.	Is the engine oil level low?	Refill the engine oil
	Is the viscosity of the engine oil low?	Replace the engine oil with the one with proper viscosity.
	Is the pressure switch out of order?	Replace the switch
	Is the oil pump out of order?	Contact dealer for repair
8. Thermostat lamp is not turned on.	Is the fuse burnt out?	Replace the fuse
9. Battery warning lamp is on during operation.	Is the regulator (current limit) out of order?	Contact dealer for repair
	Is the fan belt slack or damaged?	Adjust or replace the fan belt

CLUTCH AND BRAKE

SITUATION	INSPECTION ITEM	SOLUTION
1. The clutch slips or cannot be disconnected	Is the extent of free play of the clutch pedal proper?	Adjust the free play of the pedal
2. The brake does not work or works on one side.	Is the extent of free play of the brake pedal proper?	Adjust the free play of the pedal
3. The brake pedal squeaks and does not return well	Is the brake pedal return spring damaged?	Replace the spring
	Is each part well greased?	Remove the rust and apply grease.

HYDRAULIC SYSTEM

SITUATION	INSPECTION ITEM	SOLUTION
1. The work unit cannot be lifted	Is the hydraulic stop/slow return valve put to "Close"?	Put the hydraulic stop/slow return valve to "Open."
	Is the transmission fluid level low?	Refill the transmission fluid.
	Is the air taken in the intake pipe system?	Tighten the filter case or connection parts. Replace the pipe or O-ring if damaged.
	Is the oil filter clogged?	Clean or replace it.
	Is the hydraulic pump out of order?	Contact the dealer for repair.
	Is the control valve dusty or is the O-ring damaged?	Contact the dealer for repair.
2. The work unit cannot be lowered.	Is the cylinder damaged?	Contact the dealer for repair.
	Is the hydraulic stop/slow return valve put to "Close"?	Put the hydraulic stop/slow return valve to "Open."
	Is the control valve dusty or stuck with foreign substance?	Contact the dealer for repair.
	Is the cylinder damaged?	Contact the dealer for repair.
	Is the position control lever on the shallowest position?	Move the position control lever to the releasing direction.

ELECTRICAL SYSTEM

SITUATION	INSPECTION ITEM	SOLUTION
1. The head lamp does not turn on.	Is the bulb burnt out?	Replace the bulb.
	Is the fuse burnt out?	Replace the fuse.
	Is the cable separated from the socket?	Inspect cable.
2. The direction indicator lamp does not operate.	Is the bulb burnt out?	Replace the bulb.
	Is the fuse burnt out?	Replace the fuse.
	Is the flasher unit out of order?	Replace the flasher unit.
	Is the contact in bad condition?	Inspect and clean the grounding and terminals.
3. The lamps does not turn on.	Is the bulb burnt out?	Replace the bulb.
	Is the fuse burnt out?	Replace the fuse.
	Is the contact of the cable in bad condition?	Inspect the cable and secure the contact.
	In the switch out of order?	Replace the switch.
	Is the grounding in bad condition?	Connect the grounding cable securely to the body.
	Is the battery discharged?	Charge the battery.
4. The horn does not sound.	Is the fuse burnt out?	Replace the fuse.
	Is the horn switch contact in bad condition?	Inspect the horn switch.

9. SPECIFICATION

SPECIFICATIONS.....	9-2
TRAVEL SPEED	9-5

SPECIFICATIONS

Specification		Models	2400	2400h	2510	2510h	2610h
Engine	Maker		A1100N2 IDI NA	A1100N2 IDI NA	A1100N2 IDI NA	A1100N2 IDI NA	A1100N2 IDI NA
	Aspiration		Natural	Natural	Natural	Natural	Natural
	Emissions Standards		Tier 4	Tier 4	Tier 4	Tier 4	Tier 4
	Gross Power hp	hp(kW)	24 (18.0)	24 (18.0)	24 (18.0)	24 (18.0)	24 (18.0)
	PTO hp	hp(kW)	21 (15.7)	18 (13.5)	21 (15.7)	18 (13.5)	18 (13.5)
	No. of Cylinders		3	3	3	3	3
	Displacement	cu.in(cc)	71.7 (1,175)	71.7 (1,175)	71.7 (1,175)	71.7 (1,175)	71.7 (1,175)
	Rated Revolution	RPM	2,800	2,800	2,800	2,800	2,800
	Max Torque	lb-ft(Nm)	47.9 (65.0)	47.9 (65.0)	47.9 (65.0)	47.9 (65.0)	47.9 (65.0)
	Fuel Tank Capacity	gal(L)	6.0 (23.0)	6.0 (23.0)	6.0 (23.0)	6.0 (23.0)	6.0 (23.0)
	Fuel Consumption	gal.hr(L/hr)	1.5 (5.8)	1.5 (5.8)	1.5 (5.8)	1.5 (5.8)	1.5 (5.8)
	Air Cleaner		Dry, Element	Dry, Element	Dry, Element	Dry, Element	Dry, Element
	Alternator	12volt amp	50	50	50	50	50

Specification		Models	2400	2400h	2510	2510h	2610h
Drivetrain	Transmission		Sliding Mesh	HST	Sliding Mesh	HST	HST
	Forward/Reverse Method			HST		HST	HST
	4 Wheel Drive		2WD/4WD	2WD/4WD	2WD/4WD	2WD/4WD	2WD/4WD
	No. of Traveling Speeds		6F / 2R	2 Range	9F / 3R	3 Range	3 Range
	Forward Traveling Speed	mph(km/h)	9.9(16)	12.1(19.4)	10.3(16.6)	12.3(20.7)	16(25.8)
	Reverse Traveling Speed	mph(km/h)	3.9(6.3)	12.1(19.4)	7.6(12.2)	12.3(20.7)	16(25.8)
	Clutch		Dry Single Plate	Dry Single Plate	Dry Single Plate	Dry Single Plate	Dry Single Plate
	Brake		Wet, Multi-disc	Wet, Multi-disc	Wet, Multi-disc	Wet, Multi-disc	Wet, Multi-disc
	Differential Lock		STD	STD	STD	STD	STD
	Creeper		No	No	No	No	No
	Cruise Control		No	Standard	No	Standard	Standard
Hydraulics	Power Steering		Power Assisted Hydrostatic	Power Assisted Hydrostatic	Power Assisted Hydrostatic	Power Assisted Hydrostatic	Power Assisted Hydrostatic
	Total Hydraulic Flow (POWER STEERING+Implement)	gpm/lpm	7.4 (3.1+4.3) / 28.1 (11.7+16.4)	7.4 (3.1+4.3) / 28.1 (11.7+16.4)	7.4 (3.1+4.3) / 28.1 (11.7+16.4)	7.4 (3.1+4.3) / 28.1 (11.7+16.4)	7.4 (3.1+4.3) / 28.1 (11.7+16.4)
	Lift Control Type		N/A	Position	Position	Position	Position
	Joystick Valve		No	No	No	No	No
	Rear Remote(Port)		N/A	Option(up to 2)	Option(up to 2)	Option(up to 2)	Option(up to 2)

Specification		Models	2400	2400h	2510	2510h	2610h
3 Point Hitch	3 Point Hitch		CAT I	CAT I	CAT I	CAT I	CAT I
	Lift capacity at lift link ends	lbs(kg)	1,499 (680)	1,499 (680)	1,499 (680)	1,499 (680)	1,499 (680)
	3Point Hitch Lift Capacity @24" behind lift point	lbs(kg)	974 (442)	974 (442)	974 (442)	974 (442)	974 (442)
PTO	Rear(Mid) PTO Speed	RPM	540 / 960 (2,500)	540 / 960 (2,500)	540 / 960 (2,500)	540 / 960 (2,500)	540 / 960 (2,500)
	Rear PTO Type		Live	Live	Live	Live	Live
Tires	Front		6 - 12	6 - 12	6 - 12	6 - 12	7-16
	Rear		9.5 - 16	9.5 - 16	9.5 - 16	9.5 - 16	11.2-20
Dimensions	Wheelbase	in(mm)	59.1 (1,502)	59.1 (1,502)	59.1 (1,502)	59.1 (1,502)	65.7 (1670)
	Overall Length(W/ 3PT)	in(mm)	120.3 (3,055)	120.3 (3,055)	120.3 (3,055)	120.3 (3,055)	122.9 (3,122)
	Min.Overall Width	in(mm)	44.2 (1,124)	44.2 (1,124)	44.2 (1,124)	44.2 (1,124)	53.8 (1,369)
	Overall Height(W/ ROPS)	in(mm)	87.3 (2,219)	87.3 (2,219)	87.3 (2,219)	87.3 (2,219)	91.5 (2,328)
	Ground Clearance(4WD)	in(mm)	12.1 (307)	12.1 (307)	12.1 (307)	12.1 (307)	15.1 (382)
	Min.Turning Radius(W/ Brake)	feet(m)	9.61 (2.93)	9.61 (2.93)	9.61 (2.93)	9.61 (2.93)	9.61 (2.93)
	Turning Degree		46	46	46	46	46
Weight(W/O Front Weights)	lbs(kg)	1,792 (813)	1,829 (830)	1,792 (813)	1,829 (830)	2,106 (956)	

※ Specifications are subject to change without notice. Contact your local **TYM** dealer for more information.

TRAVEL SPEED

※ mi/h (km/h)

LEVEL		SHIFTING		2400	2400H
		MAIN	RANGE		
Forward	1	1	L	0.56 (0.90)	3.9 (6.10)
	2	2		1.06 (1.70)	
	3	3		1.86 (3.00)	
	4	1	H	3.11 (5.00)	12.1 (19.50)
	5	2		5.53 (8.90)	
	6	3		9.94 (16.00)	
Reverse	1	R	L	0.75 (1.20)	3.9 (6.10)
	2	R	H	3.91 (6.30)	12.1 (19.50)

👁️ Rated Engine rpm: 2,800 rpm, Tire: agri 9.5-16 (383 mm)

※ This specification will be changed without prior notice for improvement of quality.

※ Theory speeds figured by rated engine rpm. (mile/hr)

※ mi/h (km/h)

LEVEL		SHIFTING		2510	2510H
		MAIN	RANGE		
Forward	1	1	L	0.87 (1.40)	3.80 (6.10)
	2	2		1.24 (2.00)	
	3	3		1.80 (2.90)	
	4	1	M	1.99 (3.20)	7.00 (11.30)
	5	2		2.86 (4.60)	
	6	3		4.10 (6.60)	
	7	1	H	4.97 (8.00)	12.90 (20.80)
	8	2		7.27 (11.70)	
	9	3		10.32 (16.60)	
Reverse	1	R	L	1.30 (2.10)	3.80 (6.10)
	2	R	M	2.98 (4.80)	7.00 (11.30)
	3	R	H	7.58 (12.20)	12.9 (20.80)
☞ Rated Engine rpm: 2,800 rpm, Tire: agri 9.5-16 (383 mm)					

※ This specification will be changed without prior notice for improvement of quality.

※ Theory speeds figured by rated engine rpm. (mile/hr)

※ mi/h (km/h)

LEVEL	RANGE SHIFT	2610H
Forward	L	4.66 (7.50)
	M	8.70 (14.00)
	H	16.03 (25.80)
Reverse	L	4.66 (7.50)
	M	8.70 (14.00)
	H	16.03 (25.80)

☞ Rated Engine rpm: 2,800 rpm, Tire: agri 11.2-20 (476 mm)

※ This specification will be changed without prior notice for improvement of quality.

※ Theory speeds figured by rated engine rpm. (mile/hr)

MEMO

A series of horizontal dotted lines for writing.

10. EMISSIONS CONTROL WARRANTY

EMISSIONS CONTROL WARRANTY 10-2

EMISSIONS CONTROL WARRANTY

U.S. EPA EMISSIONS CONTROL WARRANTY STATEMENT

YOUR WARRANTY RIGHTS AND OBLIGATIONS

In accordance with 40 CFR Part 1039, TYM is pleased to explain the emission control system warranty on your engine. In the US, new engines must be designed, built and equipped to meet the stringent anti-smog standards. TYM must warrant the emission control system on your engine for the periods of time listed below provided there has been no abuse, neglect or improper maintenance of your engine. Additional conditions and responsibilities are further outlined below. Where a warrantable condition exists, TYM will repair your engine at no cost to you including diagnosis, parts and labor.

MANUFACTURER'S WARRANTY COVERAGE:

TYM warrants to the original owner, and to each subsequent owner, of a new, diesel engine that the emission control system of your engine:

1. Was designed, built and equipped so as to conform at the time of sale with all applicable regulations.

2. Is free from defects in material and workmanship which will cause such engine to fail to conform with applicable regulations for the following warranty period:

- for variable speed engines rated under 19 kW (25 HP): two (2) years or 1,500 hours of operation, whichever occurs first. In the absence of a device to measure hours of use, the engine shall be warranted for a period of two years.
- for constant speed engines rated under 37 kW (50 HP) with peak power rated at less than 3,000 RPM: five (5) years or 3,000 hours of operation, whichever occurs first. In the absence of a device to measure hours of use, the engine shall be warranted for a period of two years.
- for engines rated at or above 19 kW (25 HP): five (5) years or 3,000 hours of operation, whichever occurs first. In the absence of a device to measure hours of use, the engine shall be warranted for a period of five years.

The warranty period shall begin when the engine is placed into service.

OWNER'S WARRANTY RESPONSIBILITIES:

- This engine is designed to operate on diesel fuel only. Use of any other fuel may result in the engine no longer operating in compliance with EPA's applicable emissions requirements.
- The purchaser is responsible for initiating the warranty process. You must present the engine to a TYM dealer as soon as a problem exists.

- The use of any non-exempted add-on or modified parts shall be grounds for disallowing a warranty claim. TYM is not liable for failures of warranted parts caused by the use of a non-exempted add-on or modified part.
- The purchaser is responsible for the performance of all scheduled maintenance or repairs on this new TYM engine. TYM may deny a warranty claim if failure to perform maintenance results in the failure of a warranted part. Receipts covering the performance of regular maintenance should be retained in the event of questions arise concerning maintenance. The receipts should be transferred to each subsequent owner of the equipment with the emission warranted engines.

EMISSIONS WARRANTY EXCLUSIONS:

- Malfunctions in any part caused by misuse, abuse, improper adjustments, modifications, alteration, tampering, disconnection, improper or inadequate maintenance, or use of fuels not recommended for the engine as described in the Maintenance Manual.
- Damage resulting from accident, acts of nature or other events beyond the control of TYM.
- Loss of time, inconvenience, loss of use of equipment, engine or commercial loss.

EMISSION PARTS COVERED UNDER WARRANTY:

The following is a list of emission control parts that are covered by the Limited Emission Control System Warranty. This warranty covers include any engine parts related to the following systems:

- Fuel Injection Pump
- Fuel Injectors
- Ignition system
- Intake Manifold
- Electronic control units (if equipped)
- Sensors (if equipped)
- Exhaust Manifold
- Positive Crankcase Ventilation system parts (including PCV Valve and Oil Filler Cap)
- Turbocharger (if equipped)
- Charge air cooling system (if equipped)
- Smoke puff limiter (if equipped)
- EGR (if equipped)
- Air-induction system (e.g., intake and exhaust manifolds).
- Aftertreatment devices, if equipped (e.g., Diesel Particulate Filter [DPF], Diesel Oxidation Catalyst [DOC]).

Miscellaneous hoses, clamps, connectors and sealing gaskets or devices used in the above systems.

Emission-related components also include any other part whose only purpose is to reduce emissions or whose failure will increase emissions without significantly degrading engine/equipment performance.

MEMO

A series of horizontal dotted lines for writing.

11. INDEX

INDEX 11-2

A

ABOUT WARRANTY.....	2-1
ACCELERATOR PEDAL.....	4-3
ADJUSTING THE LOWERING SPEED OF THE IMPLEMENT	5-13
ADJUSTING WHEEL TREAD	5-21
AFTER USING THE MACHINE.....	1-13
AUX. HYDRAULICS.....	5-20

B

BATTERY.....	7-15
BATTERY CHARGE LAMP.....	4-8
BEFORE USING THE MACHINE	1-2
BRAKE	7-18
BRAKE LAMP	4-20
BRAKE PEDAL.....	4-11

C

CARRYING THE LOAD.....	5-24
CHECKING AND CHANGING OILS.....	7-7
CHECKING BEFORE OPERATION.....	5-2
CLUTCH	7-17
CLUTCH AND BRAKE.....	8-4
CLUTCH PEDAL	4-10

COLOR OF EXHAUST GAS	7-21
COOLANT	7-12
CRUISE CONTROL UNIT.....	4-12

D

DIFFERENTIAL LOCK.....	5-16
DIFFERENTIAL LOCK PEDAL.....	4-11
DRAINING AIR IN FUEL LINE	7-12
DRIVING ON THE ROAD	5-13
DRIVING ON THE SLOPE.....	5-14

E

ELECTRICAL CABLES	7-16
ELECTRICAL SYSTEM	8-6
EMERGENCY ENGINE SHUT OFF BUTTON.....	4-5
ENGINE.....	8-2
ENGINE OIL	7-7
ENGINE OIL FILTER	7-10
ENGINE OIL PRESSURE LAMP	4-8
ENTERING AND LEAVING THE PAVEMENT	5-15
EXTERIOR VIEW.....	3-2

- F**
- FAN BELT 7-19
 - FILTERS / COOLANT REPLACEMENT 7-10
 - FLOW CONTROL VALVE..... 4-17
 - F-R HST DRIVE PEDAL..... 4-12
 - FRONT AXLE..... 7-9
 - FUEL FILTER..... 7-11
 - FUEL GAUGE 4-8
 - FUEL, OIL AND COOLANT CHART..... 7-6
 - FUNCTIONS..... 4-1
 - FUSE & FUSIBLE LINKS..... 7-21
- G**
- GENERAL PRECAUTIONS..... 1-1
 - GREASING 7-17
- H**
- HANDLING LARGE HEAVY OBJECTS 5-25
 - HAZARD LAMP S/W 4-4
 - HEAD LAMP & HORN S/W 4-4
 - HEAD LAMP (HIGH BEAM)..... 4-9
 - HOUR METER..... 4-7
 - HOW TO FOLD DOWN THE ROPS 5-26
 - HYDRAULIC SYSTEM 8-5
- I**
- INDEX 10-1
 - INSTALLING 3POINT LINK 5-18
 - INSTRUMENT PANEL 4-6
- L**
- LEVER OPERATION (L) 4-16
 - LEVER OPERATION (R)..... 4-14
 - LOADER OPERATION 5-23
 - LOCATION OF SAFETY DECALS 1-26
- M**
- MAIN GEAR SHIFT LEVER..... 4-14
 - MAIN KEY SWITCH 4-2
 - MAINTENANCE AFTER WORK..... 6-1
 - MAINTENANCE AFTER WORK..... 6-2
 - MAINTENANCE BEFORE OPERATING 1-18
 - MAINTENANCE FOR PROLONGED STORAGE..... 6-2
 - MFWD LEVER..... 4-15
- O**
- OIL, GREASE AND ANTI-FREEZE CHART 7-5
 - OPENING AND CLOSING OF HOOD AND SIDE COVERS.... 7-7
 - OPERATION & WORK 5-1

O

OTHERS.....	1-19
OTHERS.....	4-18
OTHERS.....	7-14
OVERVIEW OF THE TRACTOR	3-1

P

PIPES AND HOSES	7-15
PEDALS.....	4-10
PERIODIC MAINTENANCE AND ADJUSTMENT.....	7-1
PERIODIC MAINTENANCE AND ADJUSTMENT.....	7-2
PERIODIC MAINTENANCE SCHEDULE.....	7-3
POSITION CONTROL LEVER	4-15
POWER STEERING	5-21
PRECAUTION FOR PROLONGED STORAGE	1-15
PRECAUTIONS FOR ATTACHING THE IMPLEMENT	5-19
PRECAUTIONS IN INCLINED AREA	1-17
PRE-HEAT LAMP.....	4-7
PTO SHIFT LEVER.....	4-17
PTO POSITION	4-7
PTO SPECIFICATIONS & PRECAUTIONS.....	5-22

R

RADIATOR SCREEN & AIR CLEANER ELEMENT.....	7-14
RANGE SHIFT LEVER.....	4-16
ROPS FOLDING METHOD	5-26

S

SEAT ADJUSTMENT	4-19
SEAT BELT	4-18
SIDE LAMP SWITCH	4-5
SPECIFICATION	9-1
SPECIFICATIONS.....	9-2
STARTING / STOPPING THE ENGINE	5-9
STEERING WHEEL.....	7-18
SWITCHES AND LEVERS	4-2

T

TACHOMETER	4-6
TAIL LAMP	4-19
TIRES.....	7-22
TO ENSURE SAFE OPERATION	1-2
TO RAISE OR LOWER THE IMPLEMENT	5-12
TO START THE ENGINE	5-10
TO STOP THE ENGINE	5-12
TOE-IN.....	7-20
TOWING INSTRUCTIONS	5-22
TRACTOR LOADING /UNLOADING	5-17
TRANSMISSION OIL	7-8
TRANSMISSION OIL FILTER	7-11
THROTTLE LEVER	4-3
TROUBLE SHOOTING	2-2
TROUBLE SHOOTING	8-1
TROUBLESHOOTING	8-2
TURN SIGNAL SWITCH.....	4-4
TURNING ON THE PAVEMENT	5-15

W

WARRANTY.....	2-2
WATER TEMP GAUGE	4-9
WHILE WORKING	1-11

MEMO

A series of horizontal dotted lines for writing.